

PACE EDWARDS

# RETRACTABLE UTILITY BED COVER - ELECTRIC

## INSTALLATION INSTRUCTIONS



**Pace Edwards Company**  
2400 Commercial Blvd.  
Centralia WA 98531

**(800) 338-3697 toll free**  
**(360) 736-9991 main**  
**(360) 736-9992 fax**

**[www.paceedwards.com](http://www.paceedwards.com)**

### TABLE OF CONTENTS

Required Tools.....	2
Before You Start .....	2
Optional Wiring Harness .....	2
Packaging Contents .....	2
Hardware Kit.....	3
1. Place the Canister .....	4
2. Installing the Horizontal Rails .....	4-5
3. Installing the Release System .....	5
4. Installing Drain Tubes .....	6
5. Install & Match Drill Horizontal rail clamps .....	6
6. Shim the Horizontal rail clamps .....	6
7. Bolt Down Horizontal rail clamps.....	7
8. Installing the Corner Blanket Guide.....	7
9. Installing Vertical Rails & clamps.....	8
10. Install the Wiring .....	9
11. Connecting the Wires to the Battery .....	10
12. Mounting the Top Cover .....	10
13. Lubricate the rails .....	10
14 Installing the optional manual operation switch.....	11
Helpful Maintenance Hints .....	11
Warranty Statement.....	12

## TOOLS REQUIRED FOR ASSEMBLY:

Electric Drill  
1/4" drill bit,  
1/2" drill bit  
9/32 Allen Wrench

7/16 Socket Wrench  
Phillips screw Driver #1 & #2  
Tape Measure  
Rubber mallet

## BEFORE YOU START:

Read the instructions carefully before you start. If you have questions regarding the installation of your new Utility Bedlocker™ retractable tonneau cover, please call our Technical Support Line at (800) 338-3697.

## OPTIONAL WIRING HARNESS for dashboard switch.

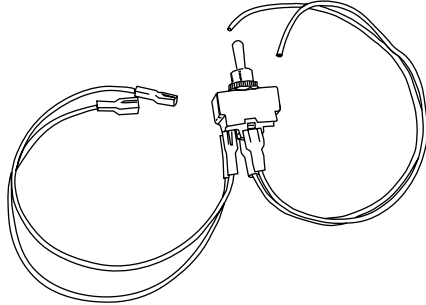

The Utility BedLocker electric retractable tonneau cover also offers an optional wire harness (**part # BL1120**) to manually operate the tonneau cover from inside the cab of your truck. This harness is designed to plug into the custom-built electronics control box. See Page 8 for installation instructions.

## PACKAGING CONTENTS:

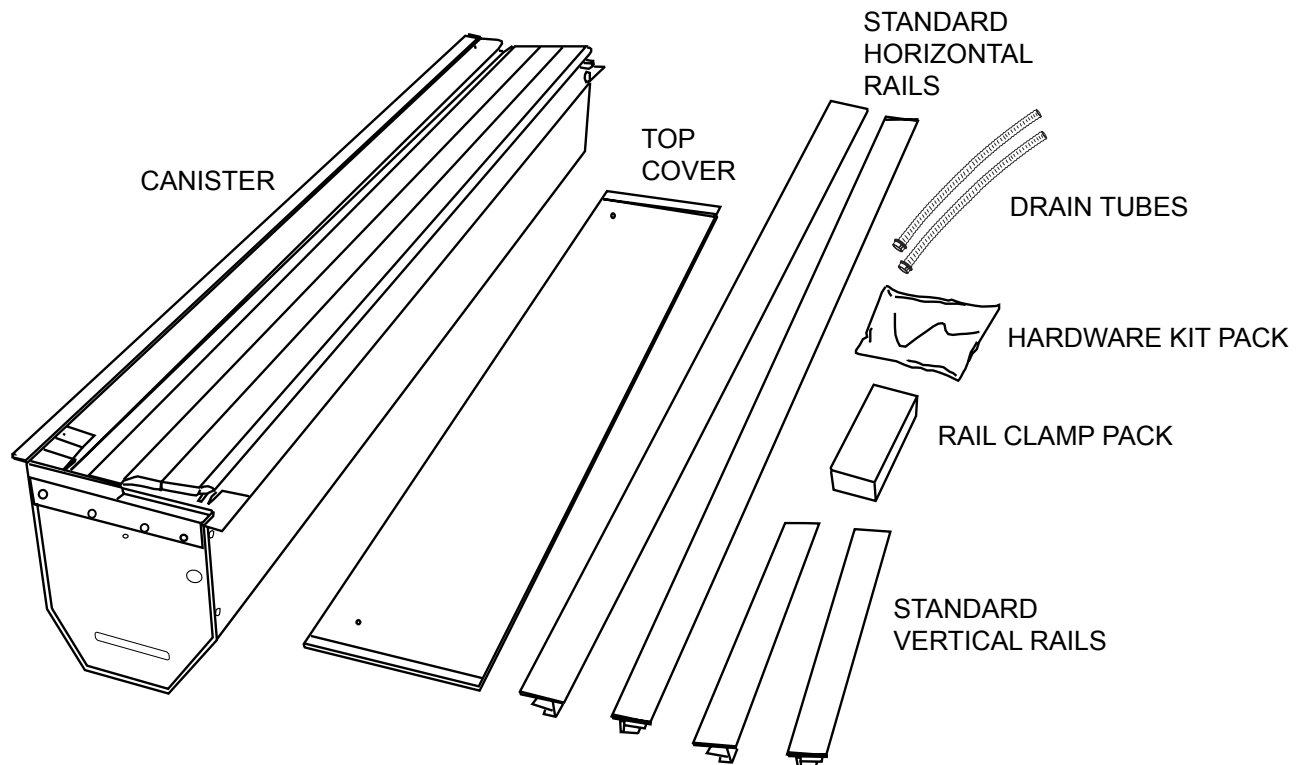

# HARDWARE KIT:

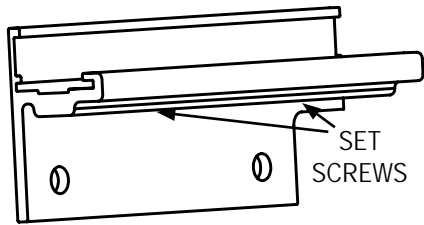

FRONT CLAMP (x 1)

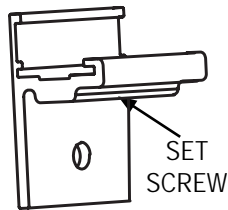

CLAMP (x9)  
w/ installed set  
screws (x9)



PLASTIC  
SHIMS (x 37)

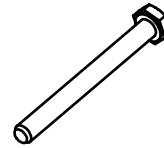

1/4-20 x 1 1/4  
CLAMP  
BOLT (x 11)

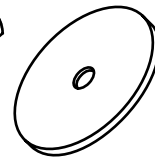

FENDER  
WASHER  
(x 12)



1/4 - 20  
NYLOCK  
(x 11)



5/16x1/16x1/2  
RUBBER  
GROMMET (x 2)

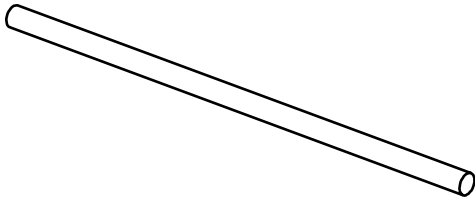

THREADED  
ROD (x 1)



SWIVEL  
COUPLER  
(x 1)



1/4" X 20  
HEX NUT  
ZP (x 1)



1/4" LOCK  
WASHER  
(x 1)



#10 x 3/4  
SHEET  
METAL  
SCREW  
(x 4)

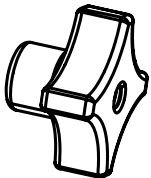

4 ARM  
KNOB (x 1)

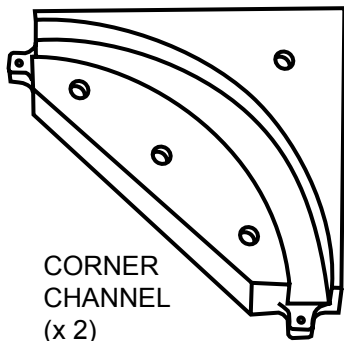

CORNER  
CHANNEL  
(x 2)



#8 x 3/4 PAN  
SQUARE TEK-  
SCREW (x 1)

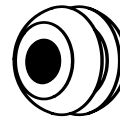

5/16x9/16x3/8x1/8  
RUBBER  
GROMMET (x 1)



CONTROL  
SWITCH (x 1)

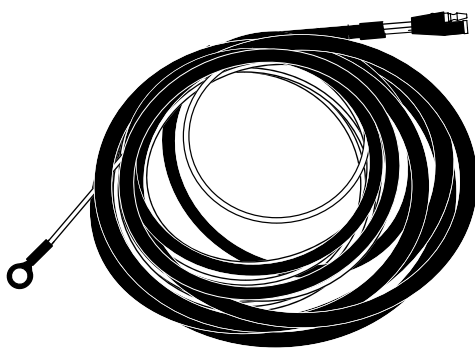

BATTERY WIRE  
HARNESS (x 1)

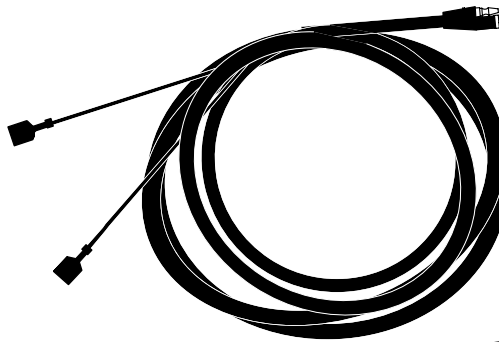

CONTROL SWITCH WIRE  
HARNESS (x 1)



WIRE CLIPS (x 4)

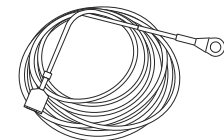

BLACK GROUND  
WIRE (x 1)



WIRE TIES (x 6)



#10-32 x 7/8 BLACK  
TOP COVER SCREW  
(x 2)

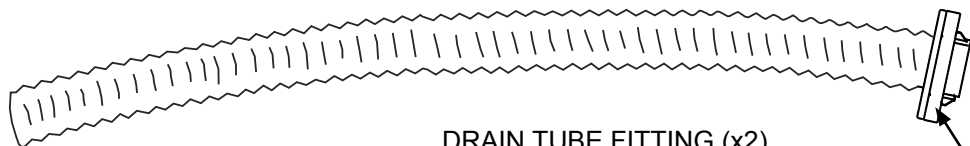

DRAIN TUBE FITTING (x2)

Foam Washer

## STEP 1. PLACE THE CANISTER



Prior to placing canister in the bed you will want to protect the paint with a couple of towels or pieces of packing foam since the fit is very tight, there is a risk of scratching the sides of the bed. Blue painters tape works well for protection also.

This will require two people. Set the canister on a stand at the front end of the bed so that the sides of the canister are above the sides of the truck bed about 3 inches. (A folding chair works well). (Fig. 1A)

Pull approximately 4-5 ribs of the cover out of the canister.

## STEP 2. INSTALLING THE HORIZONTAL RAILS SAME FOR BOTH STANDARD OR EXPLORER SERIES RAILS



***The tailgate end of the rail can damage your box during installation; we recommend wrapping the ends of the rails or protecting the sides and top of box to prevent accidental damage.***

Starting with either rail you will need to hold the rail level and slide the lower rail (**male profile**) into the rail grip (**female profile**) that is bolted to each side of the canister (Fig. 2A). You must hold the ribbed blanket out and level while sliding the rail over it and into the rail grip on the canister. **(Make sure the ribbed blanket is correctly meshed on the gear).**

When properly inserted in the rail grips on the canister push the rails all the way forward.

Once the rails are in place on both sides of the canister you can remove the protection you placed on the bed and remove the stand the canister was set on. Lowering the canister with rails attached onto the truck box. The canister will fit tight and need to be centered the truck bed.

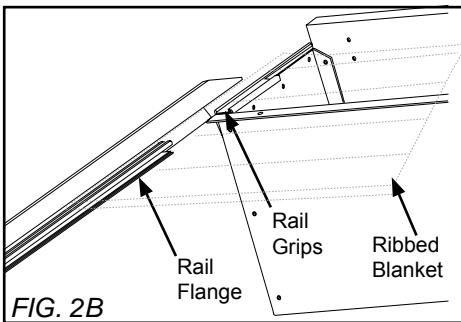

**Make sure the canister is centered in the truck bed at this point and throughout this step.**

**(Flexing the rails inward prevents the clamps from scratching the paint).**



Install the rail clamps by flexing the rails inward slightly, then slide rail clamps in the order noted. **(FIGURE 2E THE FORWARD DRIVER SIDE RAIL CLAMP IS WIDER AND HAS A NOTCH AT THE FRONT)** Slide one rail clamp all the way forward against the canister on both rails. Make sure the wider notched driver side rail clamp is used on the driver side and a regular narrow clamp is used on the passenger side. The gap between the backside of the rail clamp and the side of the truck bed will need to be shimmed.

To shim, move the rail clamp and place as many of the plastic shims between the rail and the bed sidewall as needed to fill the gap. Place the same number of shims on each side rail to maintain even centering. When the rails are shimmed slide the clamps on the rails **(Do not secure clamp set screws yet).**



With the front clamps shimmed you now need to install and shim the rail clamps at the tailgate end the same way you did for the front. Measure the width between the rails at the canister end and then at the tailgate end. This width must not be wider at the tailgate than the canister end. The width is best if shimmed 1/16<sup>th</sup> to 1/8<sup>th</sup> maximum narrower at the tailgate end.

## STEP 2. INSTALLING THE HORIZONTAL RAILS (CONT.)

FIG. 2E - DRIVERS SIDE RAIL CLAMP & COMPONENT ORDER

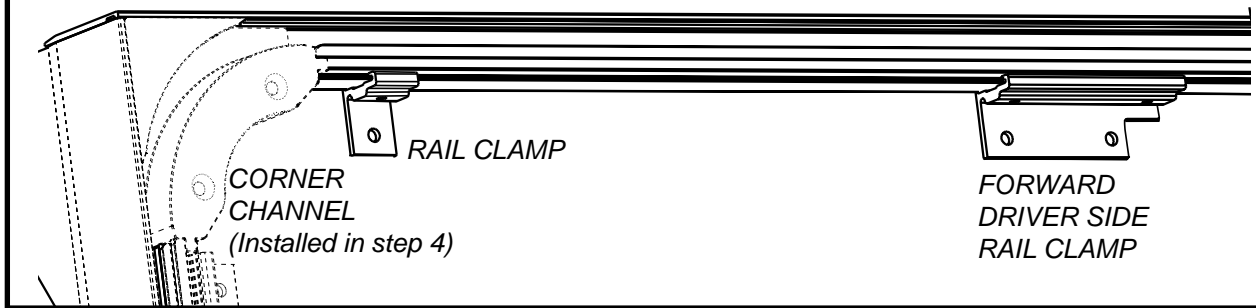

## STEP 3: INSTALLING THE RELEASE SYSTEM

After the canister is in place measure out (canister to tailgate) 1-1/8" from face of canister and 21/32"(.650) down from underside of canister lip drill a 9/16" hole in sidewall of box.

Insert rubber grommet.

Push threaded rod thru grommet until you can mate swivel coupler to release arm.

Install 6-32 bolt and nut. Tighten just enough that you let the two parts move freely. **(Over tightening will restrict movement of parts).**

Move to inside of cabinet where you will install the large washer and Four Knob handle **(flat side of knob to the outside).**

Tighten just enough to keep the knob from spinning.

If you need to use the release just turn the knob until it disengages the cover. **(Do not over tighten the knob by forcing it).** You will know when it's at the end of stroke because you will feel it tightening down.

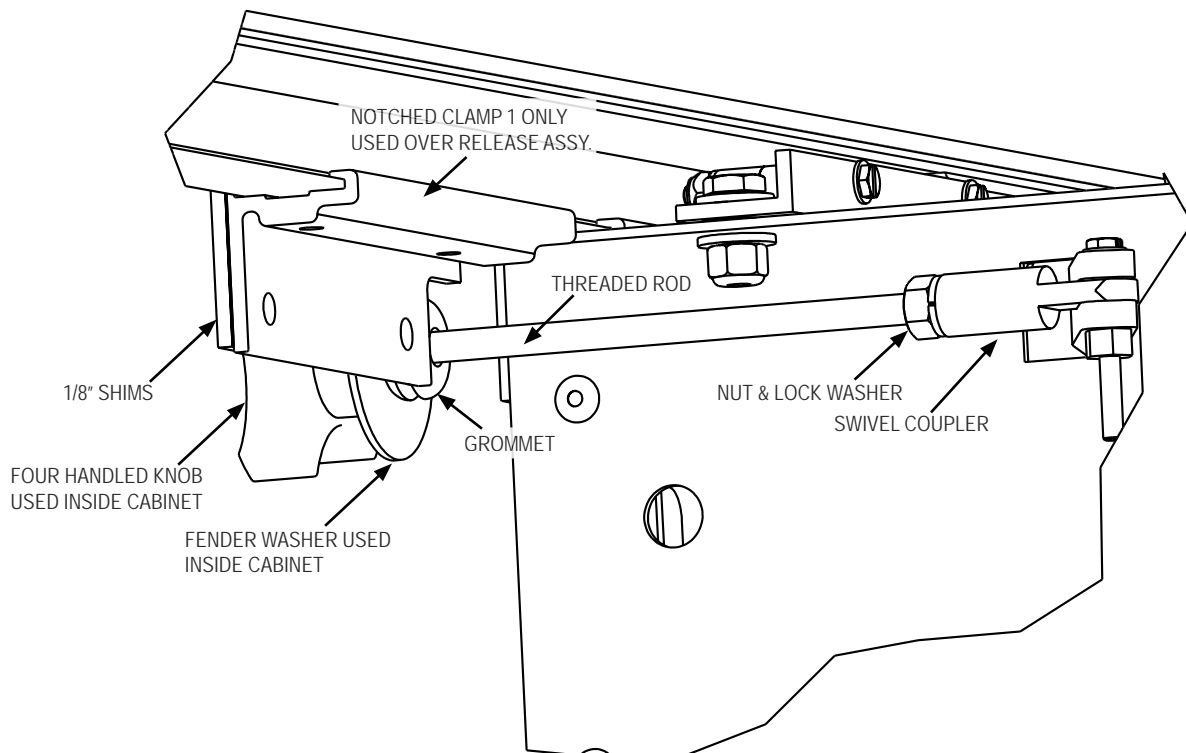

## 4. INSTALLING THE DRAIN TUBES

First ensure that the “o” ring is in place on the drain tube end being inserted into the canister. (This will prevent water leakage)

With the cover opened, insert the drain tube fittings into the pre-drilled holes on the underside of the canister by pushing them in place from under the canister.



The drain tube should click into place.

Route the end of the drain tubes out any existing drain holes present in the bed.

If no drain holes are provided you will have to drill 2 - 3/4” holes that you can push the drain hose through. **(Make sure to touch up any holes drilled to prevent corrosion).**

FIG. 4A

FIG. 4B

FIG. 4C

## 5. INSTALL AND MATCH DRILL THE HORIZONTAL RAIL CLAMPS

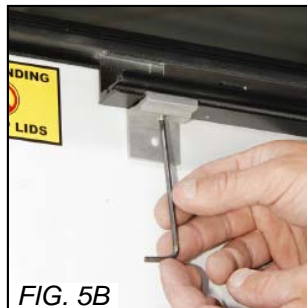

FIG. 5A

FIG. 5B

FIG. 5C

**Make sure the canister is centered in the truck bed at this point and throughout this step.**

**(Flexing the rails inward prevents the clamps from scratching the paint).**

Install the rail clamps by flexing the rails inward slightly, then slide one rail clamp all the way forward against the canister on both rails about 4”-6” from the canister. (Figure 5A) Tighten the set screw (Figure 5B) Do the same for the Middle clamp (place midway between the two other clamps) and the End clamp (Place about an inch from the corner channel) on both side rails (left and right).

Apply downward pressure to the rail and match drill the truck body with the hole in the the clamp. (Figure 5C)

## 6. SHIM THE HORIZONTAL RAIL CLAMPS (IF NEEDED)



FIG. 6A

FIG. 6B

FIG. 6C

Measure between the rails to determine the need for shims. (Figure 6A)

The gap between the backside of the rail clamp and the side of the truck bed will need to be shimmed. Remove the paper backing to expose the sticky side of the shim. (Figure 6B)

To shim, move the rail clamp and place as many of the plastic shims between the rail and the bed sidewall as needed to fill the gap. (Figure 6C) Place the same number of shims on each side rail to maintain even centering.

## 7. BOLT DOWN HORIZONTAL RAIL CLAMPS



With the rails shimmed properly

Measure the width between the rails at the canister end and then at the tailgate end. This width must not be wider at the tailgate than the canister end. The width is best if shimmed  $1/16^{\text{th}}$  to  $1/8^{\text{th}}$  maximum narrower at the tailgate end.

With a partner on the outside of the truck to help, use the  $1/4$ -20x  $1\frac{1}{4}$  Clamp Bolt, Fender washer, and  $1/4$ -20 nylock washer to secure all the clamps to the truck body. (Figure 7A & 7B)

## 8. INSTALLING CORNER BLANKET GUIDE

The Corner Channel must be shimmed, using the plastic shims provided, the same as the rails so that it is flush with the inside of the rails.

***It is essential that the horizontal and vertical rails are evenly spaced from side to side and square from front to rear by measuring and making sure all measurements are the same.***

Attach the corner channel to the horizontal rail with the 2 - 10 x  $3/4$  BLACK SHEET METAL SCREW. (Figure 8A)

Attach the corner blanket guide to the vertical rail with the 2 - 10 x  $3/4$  BLACK SHEET METAL SCREW. (Figure 8B)

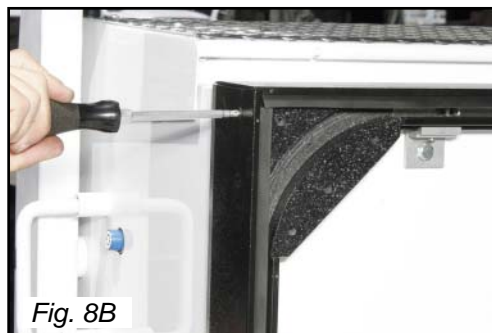
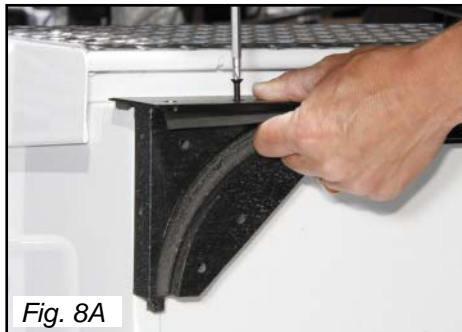

## 9. INSTALL VERTICAL RAIL CLAMPS

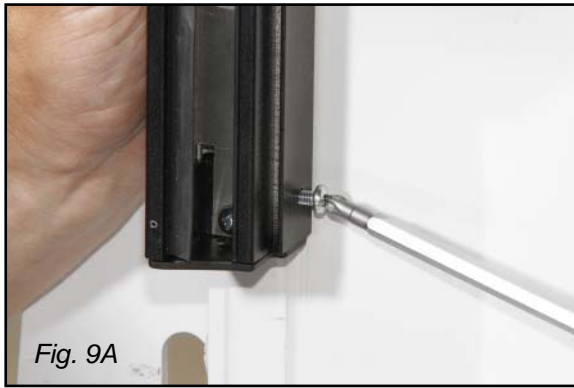

Temporarily remove the end cap screws. (Figure 9A)

Slide the clamps on the vertical rail and secure into place with the allen wrench and set screw. (Figures 9B & 9C)

Match Drill the Vertical Rail clamps to the truck body. (Figure 9D)

Add shims as needed then secure the vertical rail clamps with your partner on one side you on the other. (Figure 9E)

Secure the Vertical rail stop strip to the corner blanket guide with the #6-32-3/8 STOP STRIP CORNER SCREW (Figure 9F)

Reinstall the end cap screws in both sides. (Figure 9A)

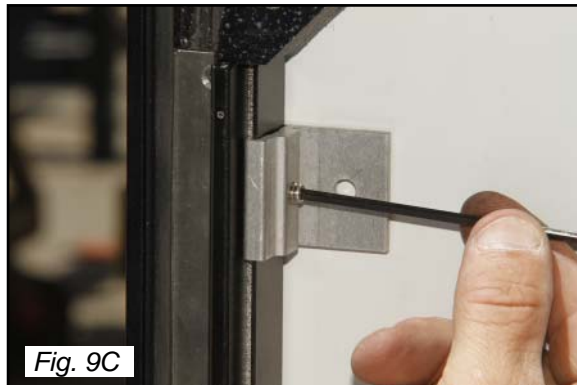
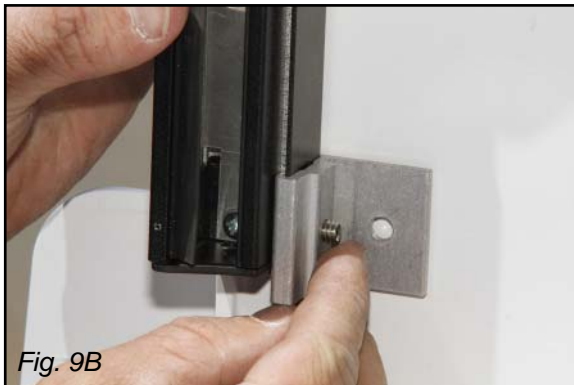

## 10. INSTALL THE WIRING

In the drivers side forward cabinet drill a ½" hole thru the sidewall of bed box about 1 inch in front of and level with the wiring exit hole in the retractable bed cover canister. (Fig. 10A)

Deburr the hole on both sides of the cabinet wall and push wires from canister into cabinet.

Slice through the rubber grommet and wrap it around the wire harness. Work the grommet into the ½" hole and pull the wire harness through to eliminate most of the slack. (Fig. 10B)

In the forward drivers cabinet, plug the wires together from the Canister Wire Harness to the Electronics Control Box

The wires are staggered in length to ease installation through the cabinet wall, plug the wires together by color.

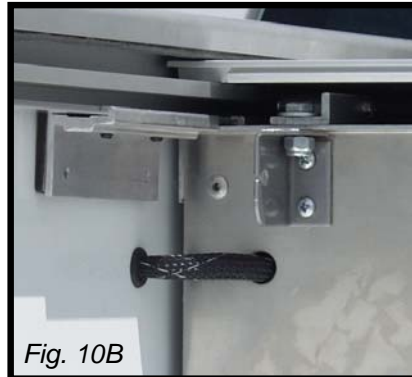

Plug the Control Switch Wire Harness into the 2-wire plug **(Without the rubber cover) (Purple/ Green)**.

Route the wire harness back to the tailgate end, rear cabinet area using any existing openings that are available.

You may need to drill between the cabinets for wire harness routing.

Use the wire clips and wire ties provided by peeling the double back tape and sticking it in place to position the wire harness as needed.

Secure the wire harness with zip ties.

Determine where you want to mount the Control Switch and drill a ½" hole **(Deburr hole on both sides of cabinet wall)**.

Mount the Control Switch.

Attach the black ground wire to the center post on the Control Switch and drill or attach ring connector to a ground (using the #8 3/4 pan square tek screw) Figure 10D.

Plug the Grey and Purple wires to the other 2 posts

**(If the switch operates the cover the opposite direction that you prefer, you only need to switch the Grey and Purple wires to correct it)**

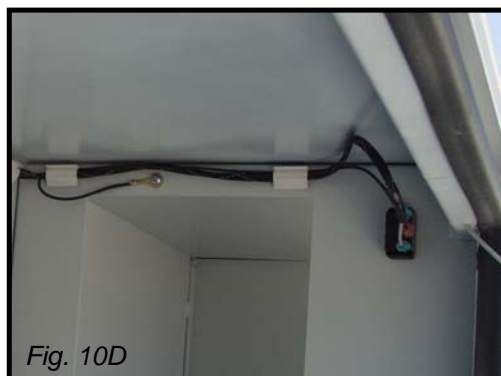

## 11. CONNECTING THE WIRES TO THE BATTERY

Plug the green and blue 2-wire battery harness into the control box.

Drill a ½" hole in the bottom of the drivers side forward cabinet, preferably in the forward innermost corner to keep the battery wire harness neatly tucked out of the way (Fig. 11A)

**Hole positions and wire harness routing will vary between box manufactures and models.**

Deburr the ½" hole on both sides of the cabinet.

Push wire harness through the hole.

Slice the rubber grommet, wrap around the harness and work into the hole to protect the wiring from the metal.

**(The Optional Manual Operation Switch should be routed at the same time as the battery harness).**

Route this wire harness along the frame and up into the battery compartment.

Attach the wire harness using wire ties provided (keep away from hot surfaces).

Attach Red (+) wire to positive 12V battery block and the Black (-) to appropriate ground.

(Ring connectors provided may need to be cut down or replaced due to bolt and attachment variations found on different vehicles.

Coil excess wiring and secure with a wire tie in the engine compartment.

Your Utility Bedlocker cover should run at this time. Check for correct operation by operating all switches installed.



Fig. 11A

## 12. INSTALL THE TOP COVER

Install the top cover on the canister making sure it is flush with the horizontal rail. Use the 2-Black Top Cover Screws.



## 13. LUBRICATE THE RAILS

Use the included 303 protectant to lubricate the sweep seal and wear strip. This ensures the cover glides smoothly the first time it is very important to lubricate the seals on the rails. You will need to periodically lubricate these seals throughout the life of the cover. We recommend using the 303 Brand protectant.



## 14. INSTALLING THE OPTIONAL MANUAL OPERATION SWITCH (Part # BL1120)

Route the (Optional) Manual Operation Switch wiring through the firewall of the truck and pull the harness into the cab.

Coil the excess wire harness and tie out of the way.

Drill and mount the switch bracket at a convenient position under the dash.

Snap the rocker switch into the switch bracket.

Place ground wire onto center post of rocker switch and attach opposite end to a ground.

Crimp the female spade connectors to the Grey and Purple wires.

Attach the crimped wire to the remaining switch posts.

**(If cover runs in opposite direction than you prefer, just switch the Grey and Purple wires).**

Your Utility Bed Cover should run at this time. Check for correct operation by operating all switches installed.

## HELPFUL MAINTENANCE HINTS

To assure quiet, smooth operation, apply a small amount of grease to the guide strips where the metal end of the panels and the guide strips meet. This initial application should be sufficient for a year or more. Regrease the guide strips if the cover begins squeaking during use.

Drain tubes may become clogged over time and should be removed and cleaned.

Periodically remove the top cover and clean out the canister.

To help keep the tonneau cover looking its best, we recommend washing it the same as caring for your truck finish.

If you have any questions please call our Technical Support at (800) 338-3697.

# CONGRATULATIONS!

We are confident that you will get many years of trouble free service from this accessory to your truck. Please take a moment to fill out the warranty registration form to activate warranty coverage of your truck bed cover.

On your purchase of a Pace Edwards Retractable Truck Bed Cover.

## PACE EDWARDS PRODUCT WARRANTY

PACE EDWARDS (hereinafter referred to as the MFG.) warrants each new Pace Edwards Bedlocker®, JackRabbit®, Full-Metal-JackRabbit™, and Roll-Top-Cover® retractable truck bed cover to the original owner as follows:

### FOR A PERIOD OF THREE (3) YEARS FROM THE DATE THE UNIT IS DELIVERED TO THE FIRST PURCHASER OR PLACED INTO SERVICE AS A DEMONSTRATOR OR COMPANY UNIT:

- Delamination of the ArmorTek deck
- Separation of the Bedlocker/Full Metal deck panels
- Failure of the Continuous Tension Spring
- Failure of the Bedlocker drive system
- All lock assemblies
- All hardware and components

### ITEMS NOT COVERED UNDER WARRANTY FOR ANY PERIOD OF TIME:

- Rips, tears, or discoloration of the ArmorTek deck material
- Seals and gaskets
- Water intrusion from any source
- Dealer and/or purchaser installed parts and accessories

### CERTAIN CONDITIONS WILL VOID ALL WARRANTY.

These conditions include:

- Use for any purpose other than normal private use including rental and promotion
- Altering the retractable truck bed cover in any manner without written approval of the MFG
- Misuse, negligence or accident
- Installation of any part or accessory without written approval from the MFG
- Failure to register this warranty with the MFG within fourteen (14) days from date of delivery

### CLAIM PROCEDURE

If a part fails, the purchaser should return to the selling dealer to determine if the failed part is covered under the terms of this warranty. If a Warranty Claim is necessary, the dealer will contact Pace Edwards to obtain A Return Goods Authorization. If it is impractical for the purchaser to return to the selling dealer, then the purchaser may contact the Pace Edwards Technical Assistance Help Desk at 1-800-338-3697 to determine warranty eligibility. In either event, it is the responsibility of the purchaser to obtain a Return Goods Authorization prior to returning the defective part to the MFG. The defective part, along with a copy of the original Bill of Sale and the Pace Edwards issued RGA #, must be returned PREPAID to Pace Edwards Co. 2400 Commercial Blvd. Centralia, WA 98531. After determining the validity of the warranty claim, PACE EDWARDS will ship a replacement part prepaid to the customer. Labor costs to replace defective parts are the responsibility of the purchaser.

### CONDITIONS AND LIMITATIONS

This warranty is subject to certain conditions and limitations including, but not limited to, the following:

- Any part of a Pace Edwards retractable truck bed cover that is found to be defective under the terms of this warranty will be repaired or replaced using either new or reconditioned parts at the discretion of the MFG.
- In determining what constitutes a failure under the terms of this warranty the decision of the MFG shall be final.
- This warranty is extended to the original purchaser only and is not transferable to subsequent purchasers.
- The MFG does not accept any responsibility in connection with the installation of any of its products by its dealers or agents.
- The MFG does not undertake responsibility to any purchaser for warranty express or implied by any of its dealers, distributors or agents beyond that which is contained herein.
- Without regard to an alleged defect of its products the MFG under any circumstances does not assume responsibility for loss of time, inconvenience, revenue, or other consequential damage including, but not limited to, expenses for telephone, food, lodging, travel, loss or damage to the vehicle the products are installed on or loss or damage to personal property of the purchaser or user of the products.
- The MFG reserves the right to make changes in the design of, improvements to, or warranty of its products without imposing any obligation upon itself to provide the same for any products theretofore manufactured.

*Some jurisdictions do not allow limitations on or exclusions to warranties, therefore some of the exclusions may not apply to you. This warranty affords you specific legal rights. You may have other legal rights that may vary from jurisdiction to jurisdiction.*

## WARRANTY REGISTRATION

Please return this completed warranty registration within 14-days to:

Or go online and register your warranty at:

<http://www.pace-edwards.com/Warranty-Care>

**Pace Edwards  
Attn: Warranty Dept.  
2400 Commercial Blvd.  
Centralia, WA 98531**



NAME: \_\_\_\_\_

ADDRESS: \_\_\_\_\_

CITY: \_\_\_\_\_ PROV./STATE: \_\_\_\_\_ PC/ZIP: \_\_\_\_\_

MODEL #: \_\_\_\_\_ SERIAL #: \_\_\_\_\_

DATE OF PURCHASE: \_\_\_\_\_ PURCHASED FROM: \_\_\_\_\_ PRICE PAID: \_\_\_\_\_

CUSTOMER SIGNATURE: \_\_\_\_\_