

ROLL-TOP-COVER®

RETRACTABLE HARD TRUCK BED COVERS

COLORADO CREW CAB INSTALLATION INSTRUCTIONS



#1 RETRACTABLE TRUCK BED COVER

(800) 338-3697
www.paceedwards.com

Pace Edwards Company
2400 Commercial Blvd.
Centralia WA 98531

TABLE OF CONTENTS

| | |
|---|---|
| Tools Required for Assembly | 2 |
| Before You Start | 2 |
| Drain Hole Locations | 2 |
| Packaging Contents | 2 |
| STEP 1: Remove Contents from Box | 2 |
| STEP 2: Place Canister | 3 |
| STEP 3: Install & Fasten Rails | 3 |
| STEP 4: Install Guide Strips | 4 |
| STEP 5: Adjust Position of Canister | 4 |
| STEP 6: Lubricating Sweep Seal | 4 |
| STEP 7: Install Lock Arm Assembly | 5 |
| STEP 8: Adjust Position of Guide Strips | 6 |
| STEP 9: Adjust Lock Arm Assembly | 6 |
| STEP 10: Install Drain Tubes | 7 |
| STEP 11: Install Top Cover | 7 |
| Helpful Maintenance Hints | 7 |
| Warranty Statement..... | 8 |

TOOLS REQUIRED FOR ASSEMBLY:

7/16" wrench or socket 3/32" Allen wrench
5/16" wrench or socket #2 Phillips screwdriver
7/8" socket, ratchet Wire cutters

**If you purchased the clamp on rail option, no drilling or punching will be required.*

BEFORE YOU START:

Read the instructions carefully before you start. These instructions are written for one-person installation. We have noted where briefly having an extra person's assistance can make installation easier. If you have questions regarding the installation please call our Technical Support Line at (800) 338-3697.

DRAIN HOLE LOCATIONS:

The Roll-Top-Cover® is designed to carry rainwater from the cover into the canister and then out through the drains. Most truck models have standard OE drain holes or plastic/rubber access ports in the front of the truck bed. Check to make sure your truck has the OE drain holes so that drilling into the sheet metal is not required. If drilling is necessary, be sure to check the underside of the truck bed for the best location. The holes should be located near the side and as far forward as possible. Use a drill bit suitable for sheet metal (such as a taper drill or step drill). Drill drain tube clearance holes at 3/4" (19mm). This will need to be done before installing the cover.

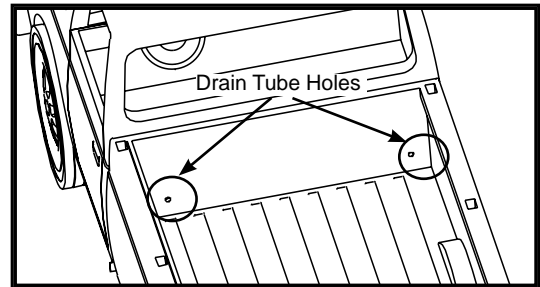

PACKAGING CONTENTS:

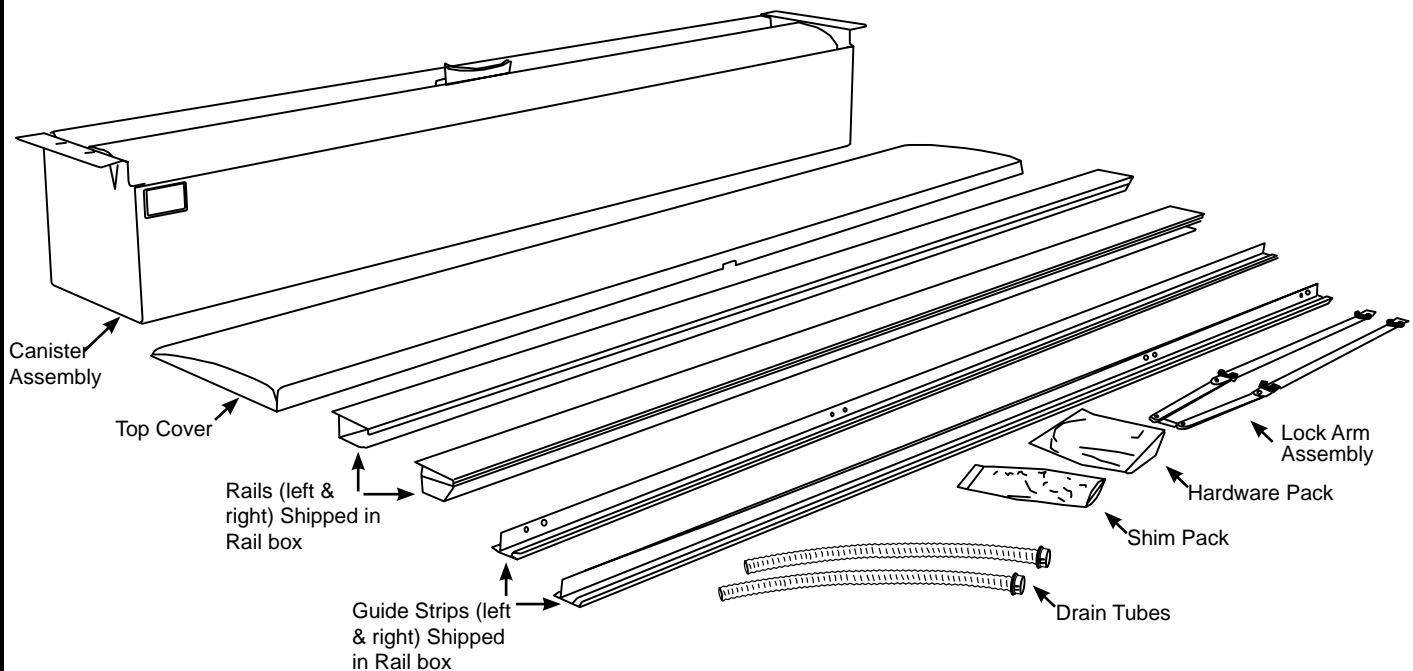

STEP 1: REMOVE CONTENTS FROM THE BOX

Remove canister and top cover from the large box. Remove rails and Guide strips from the Rail box. Perform a quick inventory to insure all parts are there. (If any parts are missing call Pace Edwards Technical Support for replacement, (800) 338-3697.)

CAUTION!

PERMANENT DAMAGE MAY BE CAUSED IF THE HANDLE ASSEMBLY IS ALLOWED TO RETRACT INTO THE CANISTER WITHOUT PROTECTION ON THE UNDERSIDE OF THE FABRIC PANEL!

CAUTION!

STEP 2: PLACE CANISTER

Use a soft rag or some packing materials from the box to wedge between the fabric roll and handle to temporarily keep the fabric roll from winding into the canister.

Place the canister in the front of the truck bed, cab side forward, in the position required for unrolling. The canister should be resting on the canister end plates and be centered from side to side in the truck bed. Do not attach the canister yet.

INSTALL TIP!

TO MAKE RAIL INSTALLATION EASIER YOU MAY WANT TO HAVE ANOTHER PERSON HOLD THE RAILS IN PLACE WHILE YOU ARE TIGHTENING THE CLAMPS. YOU CAN ALSO TEMPORARILY TAPE THE RAILS IN PLACE WHILE TIGHTENING THE CLAMPS IF ANOTHER PERSON IS NOT AVAILABLE.

INSTALL TIP!

STEP 3: INSTALL & FASTEN THE RAILS

HARDWARE USED:



PLASTIC SHIMS x 8

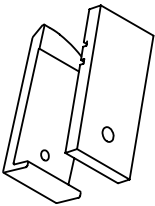

OUTER & INNER RAIL CLAMPS x 4



1/4" FLAT WASHER x 4



1/4" LOCK WASHER x 4



RAIL CLAMP BOLT x 4

Side rails have a rubber spacer on the end caps, at the tailgate end, to establish the correct spacing to the tailgate (1/16") and to prevent the tailgate from striking the side rails when closing. Press the rail tightly against the closed tailgate.

Shims may be required to maintain a horizontal top surface on the rails. Peel and stick the shims to the back side of the rail brackets (or the side that will be against the truck).

Shims are provided in two thicknesses. Shims may need to be stacked on each other to create the right thickness. Repeat the same process on each side.

Place the four (4) clamps over the brackets located on the underside of the rails.

Locate the UPPER groove of the inner clamp bracket onto the lip of the rail bracket (as shown in Figure 3).

Rotate the outer clamp bracket clockwise to tighten rail downward against bed rail. Tighten bolt securely.

Apply downward pressure while tightening the clamps on the rails, especially on the tailgate end. This will ensure a tight seal, firm seat, and good fit on the truck bed.

(Adjust pressure against tailgate by moving rails forward or backward as needed prior to final tightening of clamps.)

Repeat for all clamps.

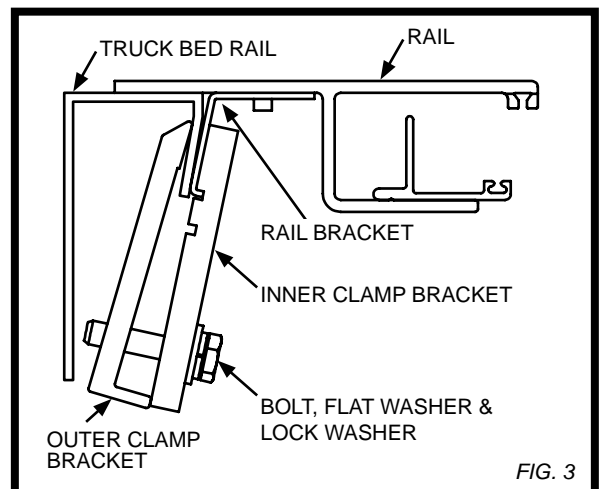

FIG. 3

DO NOT TIGHTEN OVER 120-INCH POUNDS!

STEP 4: INSTALL THE GUIDE STRIPS

HARDWARE USED:



#8 MACHINE SCREW x 16

Install the guide strips in the side rails.

Be sure the "left" and "right" guide strips are installed on the correct sides.

Loosely screw the guide strips to the side rails from the bottom with the #8 machine screws provided (Do not tighten yet). (Figure 4a & 4b)

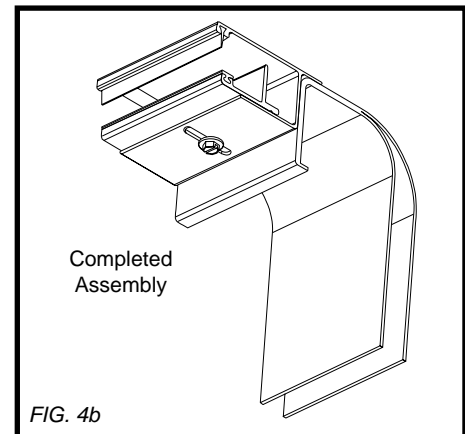
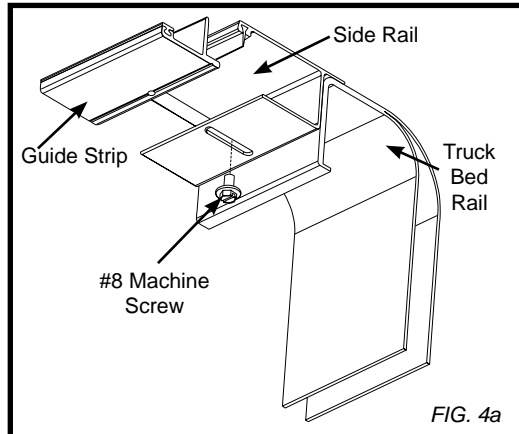

STEP 5: FASTEN CANISTER

HARDWARE USED:

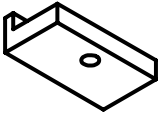

CANISTER CLAMP x 2

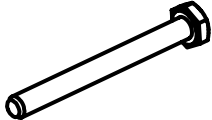

CLAMP BOLT
(1/4"-20 x 2 3/4") x 2



CLAMP WASHER x 2

Center the canister side-to-side on the truck bed and fasten it in place with the canister clamps.

Use one clamp per side of canister.

Install 1/4" - 20 x 2 3/4" bolt with fender washer through one of the slots in each end of the canister and attach the Canister Clamp. (Figure 5)

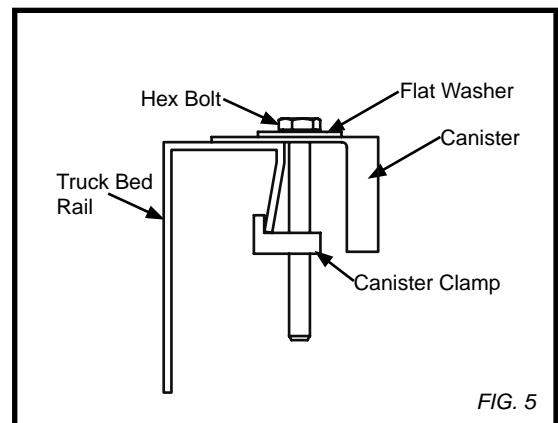

STEP 6: LUBRICATING & PLACING THE SWEEP SEALS

Locate the sweep seals (rubber weather strips) on the rails. Apply Pace Edwards' UV Protectant (or 303 brand protectant) to a rag and wipe the underside of the sweep seal and the top of the wear strip.

Carefully remove the ZIP tie securing the cover to the canister we recommend using the wire cutters for this. Roll the handle down into the ends of the rails and down to the tailgate. Using an Allen wrench (if necessary) to carefully draw out the sweep seal (seal should be angled outwards toward the cover – not rolled in toward the bed rail). (Figure 6)

Proper care and placement of the sweep seal will ensure smooth operation of the cover. Remove the protective foam cover from the underside of the fabric panel. Remove the protective film from the inside back of the canister.

DO NOT ALLOW THE HANDLE TO ROLL INTO THE CANISTER AS PERMANENT DAMAGE MAY OCCUR TO THE FABRIC.

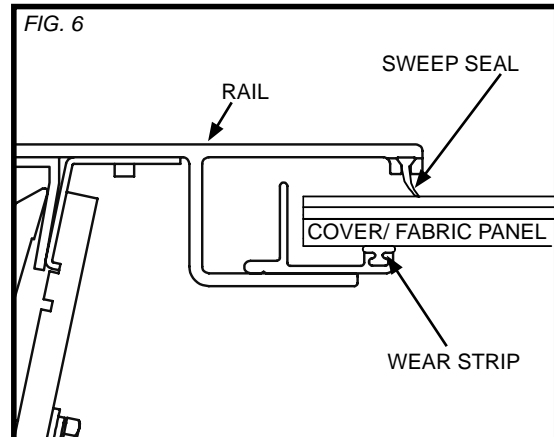

! PERMANENT DAMAGE MAY BE CAUSED IF THE HANDLE ASSEMBLY IS ALLOWED TO RETRACT INTO THE CANISTER WITHOUT PROTECTION ON THE UNDERSIDE OF THE FABRIC PANEL !

CAUTION!

! YOU MUST PROTECT THE FABRIC FROM THE LOCK ASSEMBLY !

CAUTION!

! DO NOT BEND THE COVER BACKWARDS AGAINST THE ROLL UP DIRECTION AS IRREPARABLE DAMAGE MAY OCCUR !

STEP 7: INSTALL LOCK ARM ASSEMBLY

HARDWARE USED:

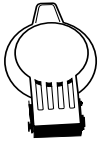

LOCK COVER x 1

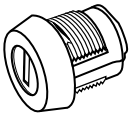

LOCK x 1



LOCK NUT x 1



LOCK KEYS x 2



LOCK ASSEMBLY SCREW x 1

Unroll the cover by pulling the handle, at the end of the fabric panel assembly into the side rails all the way to the tailgate end of the truck bed.

Install the Lock Arm Assembly by sliding the black plastic blocks into the lengthwise groove on the underside of the handle. (Figure 7a & 7b)

Remove the Lock Nut from the Lock and insert the Lock through the Lock Cover and the center hole in the handle.

Install and securely tighten the Lock Nut with the needle nose pliers until the Lock pulls into the fabric and meets resistance to turning.

Attach the lock cam of the lock arm assembly to the lock by engaging the square hole with the square lug on the lock. (Figure 7c)

Install and tighten the Lock Assembly Screw. Test to see that turning the key moves the arms in and out. If not, remove the Lock Assembly Screw and rotate the lock cam 90 degrees and refasten.

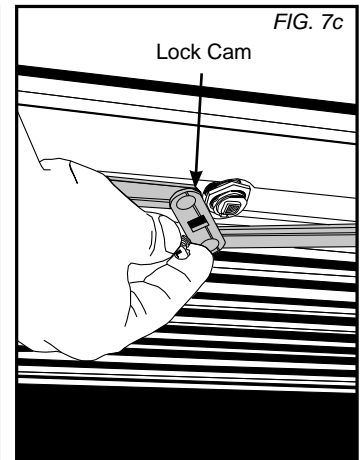
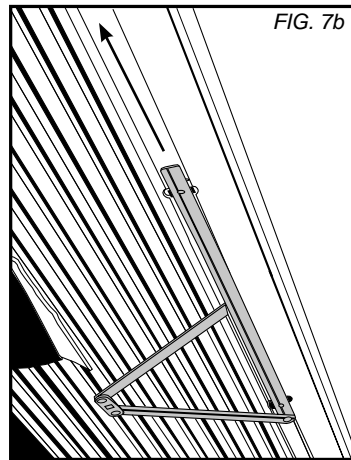
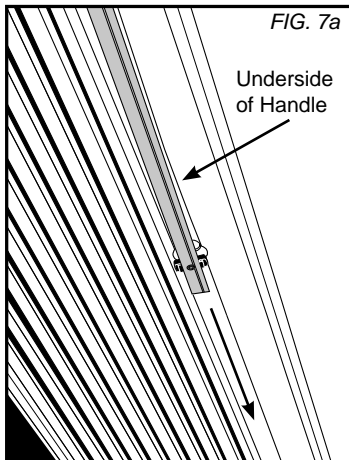

STEP 8: ADJUST POSITIONING OF GUIDE STRIPS

Allow the cover to retract to the first guide strip screws (nearest the canister).

Align the vertical portion of the guide strip with the cover assembly leaving 1/8" (3mm) clearance between the two. (Figure 8) This will allow for heat expansion of the aluminum panels on the cover.

Tighten the first (nearest canister) guide strip screws on both sides. Next, pull the handle to the guide strip screws nearest the tailgate, align with 1/8" (3mm) clearance on either side and tighten these screws.

Close the tailgate and the cover.

Make sure that the seal in the handle is making contact along the entire length of the tailgate.

If it is not this means the truck bed is not square. Compensate for this by adjusting the guide strips left or right.

Test again to make sure there is 1/8" clearance on either side of the cover.

Retract the cover back towards the canister and tighten the remaining guide strip screws.

Check again to make sure that the cover moves in and out freely without binding. (If not, readjust accordingly.)

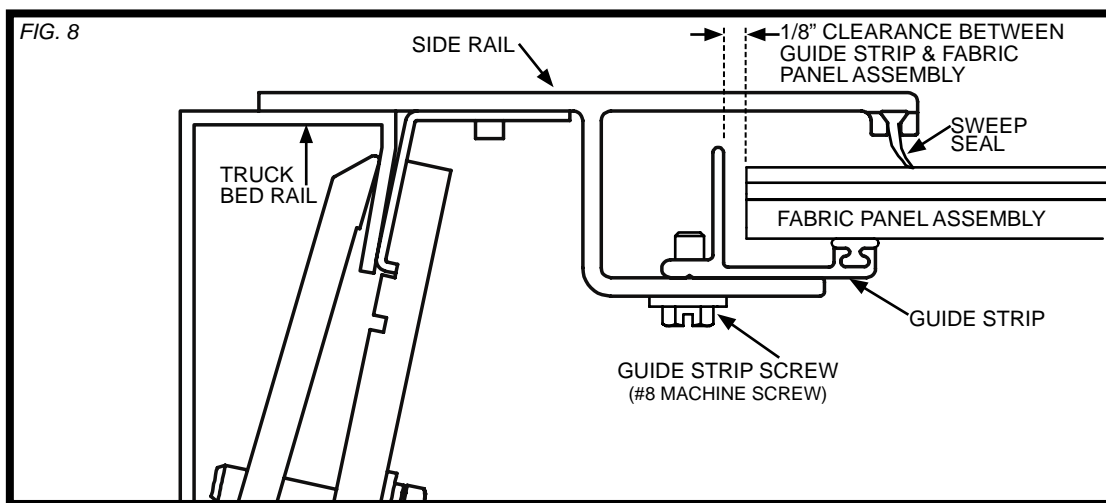

STEP 9: ADJUST LOCK ARM (IF NECESSARY)

Check the lock function. If the rails were installed correctly, the handle will fit against the tailgate snugly.

If the fit is too loose or too tight, there is an adjustment you can do to correct this.

The lock arms enter a plastic receiver in the guide strips. The receivers are adjustable to fine-tune the fit to the tailgate.

To adjust the receivers, lock your cover at the 18" forward lock position.

Look into the rail opening by the tailgate. There are two small Phillips screw heads showing. Loosen them slightly on both sides.

Unlock the cover and relock it at the tailgate.

Pull the handle back firmly on both sides until a snug fit against the tailgate is achieved.

Hold the cover in this position and unlock it.

Move the cover back to the 18" lock position.

Tighten the Phillips screws.

STEP 10: INSTALLING DRAIN TUBES

First ensure that the “o” ring is in place on the drain tube end being inserted into the canister (This will prevent water leakage). Test fit the drain tube to determine the length you want to trim it. Always caution on the long side. Trim the end that will be inserted through the truck bed with the wire cutters or a utility knife.

With the cover *opened*, insert the drain tube fittings into the pre-drilled holes on the underside of the canister by pushing them in place from under the canister. Drain tube should click into place.

Place the other end of the drain tube through the plastic/ rubber access port or through the pre-drilled holes in the floor or the front wall of the truck bed.

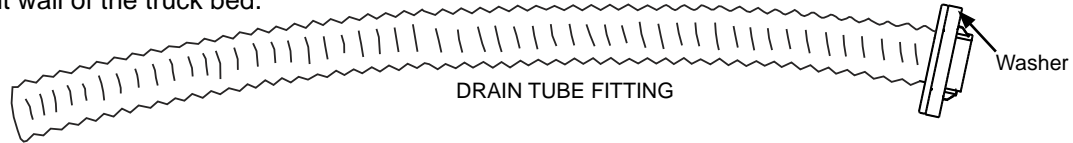

NOTE: If the OE access ports are located on the front wall of the truck bed you should ensure that the drain-tubes are inserted and directed down so water flows out of the truck.

STEP 11: ATTACHING TOP COVER

HARDWARE USED:



PLASTIC CANISTER INSERTS X 4



TOP COVER SCREW X 4

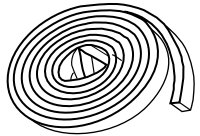

FOAM

Insert the plastic canister inserts into the square holes located on either side of the canister.

Install the canister top cover with the four long Top Cover screws.

Tighten the screws until the cover is just touching the truck bed. **Do not over tighten.**

Be sure the high side showing the Roll-Top-Cover® label faces the tailgate.

Foam is provided in specific applications to close up the front of the top cover if needed.

HELPFUL MAINTENANCE HINTS

To assure quiet, smooth operation, apply a small amount of grease to the guide strips where the metal end of the panels and the guide strips meet. This initial application should be sufficient for a year or more. Regrease the guide strips if the cover begins squeaking during use.

After installation, if the cover is tight or hard to open and close, the positioning in Step 7 may need to be redone. Over a period of time, if the cover becomes difficult to move in or out (particularly on hot days), check that the side-to-side clearance on the Roll-Top-Cover is set at 1/8" or more.

Periodically remove the Top Cover and clean out the canister.

It is important to open and close the cover regularly; the spring that operates the cover is self-lubricated and regular use assures that it stays in proper working condition.

Drain tubes may become clogged overtime and should be removed and cleaned. To remove the drain tubes you must; Remove the Top Cover, close the cover to the tailgate, reach in the canister and depress the plastic retaining tabs on the drain tube fittings and push the drain tube out of the hole in the bottom of the canister. (Fig. 1)

To help keep the Roll-Top-Cover looking it's best, we recommend washing it the same as caring for your truck finish. However you should not wax your cover. Using a citrus-based vinyl cleaner and protectant such as Pace Edwards Brand or the 303 brand will keep your cover looking like new. Alcohol, petroleum based or silicon-based cleaners such as Armor-All should be avoided and ARE NOT recommended for our covers.

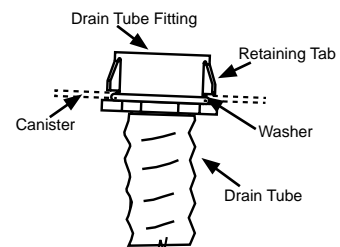

CONGRATULATIONS!

On your purchase of a Pace Edwards Retractable Truck Bed Cover. We are confident that you will get many years of trouble free service from this accessory to your truck. Please take a moment to fill out the warranty registration form to activate warranty coverage of your truck bed cover.

PACE EDWARDS PRODUCT WARRANTY

PACE EDWARDS (hereinafter referred to as the MFG.) warrants each new Pace Edwards Bedlocker®, JackRabbit®, Full-Metal-JackRabbit™, and Roll-Top-Cover® retractable truck bed cover to the original owner as follows:

FOR A PERIOD OF THREE (3) YEARS FROM THE DATE THE UNIT IS DELIVERED TO THE FIRST PURCHASER OR PLACED INTO SERVICE AS A DEMONSTRATOR OR COMPANY UNIT:

- Delamination of the ArmorTek deck
- Separation of the Bedlocker/Full Metal deck panels
- Failure of the Continuous Tension Spring
- Failure of the Bedlocker drive system
- All lock assemblies
- All hardware and components

ITEMS NOT COVERED UNDER WARRANTY FOR ANY PERIOD OF TIME:

- Rips, tears, or discoloration of the ArmorTek deck material
- Seals and gaskets
- Water intrusion from any source
- Dealer and/or purchaser installed parts and accessories

CERTAIN CONDITIONS WILL VOID ALL WARRANTY.

These conditions include:

- Use for any purpose other than normal private use including rental and promotion
- Altering the retractable truck bed cover in any manner without written approval of the MFG
- Misuse, negligence or accident
- Installation of any part or accessory without written approval from the MFG
- Failure to register this warranty with the MFG within fourteen (14) days from date of delivery

CLAIM PROCEDURE

If a part fails, the purchaser should return to the selling dealer to determine if the failed part is covered under the terms of this warranty. If a Warranty Claim is necessary, the dealer will contact Pace Edwards to obtain A Return Goods Authorization. If it is impractical for the purchaser to return to the selling dealer, then the purchaser may contact the Pace Edwards Technical Assistance Help Desk at 1-800-338-3697 to determine warranty eligibility. In either event, it is the responsibility of the purchaser to obtain a Return Goods Authorization prior to returning the defective part to the MFG. The defective part, along with a copy of the original Bill of Sale and the Pace Edwards issued RGA #, must be returned PREPAID to Pace Edwards Co. 2400 Commercial Blvd. Centralia, WA 98531. After determining the validity of the warranty claim, PACE EDWARDS will ship a replacement part prepaid to the customer. Labor costs to replace defective parts are the responsibility of the purchaser.

CONDITIONS AND LIMITATIONS

This warranty is subject to certain conditions and limitations including, but not limited to, the following:

- Any part of a Pace Edwards retractable truck bed cover that is found to be defective under the terms of this warranty will be repaired or replaced using either new or reconditioned parts at the discretion of the MFG.
- In determining what constitutes a failure under the terms of this warranty the decision of the MFG shall be final.
- This warranty is extended to the original purchaser only and is not transferable to subsequent purchasers.
- The MFG does not accept any responsibility in connection with the installation of any of its products by its dealers or agents.
- The MFG does not undertake responsibility to any purchaser for warranty express or implied by any of its dealers, distributors or agents beyond that which is contained herein.
- Without regard to an alleged defect of its products the MFG under any circumstances does not assume responsibility for loss of time, inconvenience, revenue, or other consequential damage including, but not limited to, expenses for telephone, food, lodging, travel, loss or damage to the vehicle the products are installed on or loss or damage to personal property of the purchaser or user of the products.
- The MFG reserves the right to make changes in the design of, improvements to, or warranty of its products without imposing any obligation upon itself to provide the same for any products theretofore manufactured.

Some jurisdictions do not allow limitations on or exclusions to warranties, therefore some of the exclusions may not apply to you. This warranty affords you specific legal rights. You may have other legal rights that may vary from jurisdiction to jurisdiction.

WARRANTY REGISTRATION

Please return this completed warranty registration within 14-days to:

Or go online and register your warranty at:

www.paceedwards.com/warranty-care

Pace Edwards
Attn: Warranty Dept.
2400 Commercial Blvd.
Centralia, WA 98531



NAME: _____

ADDRESS: _____

CITY: _____ PROV./STATE: _____ PC/ZIP: _____

MODEL #: _____ SERIAL #: _____

DATE OF PURCHASE: _____ PURCHASED FROM: _____ PRICE PAID: _____

CUSTOMER SIGNATURE: _____