

# 2004 - Current FORD FLARESIDE

## RAIL & CLAMP SUPPLEMENT INSTRUCTIONS

### LEVELING THE RAILS:

1. To level the rails it is necessary to add a shim between the rail and the front bed sill. (Figure 1)

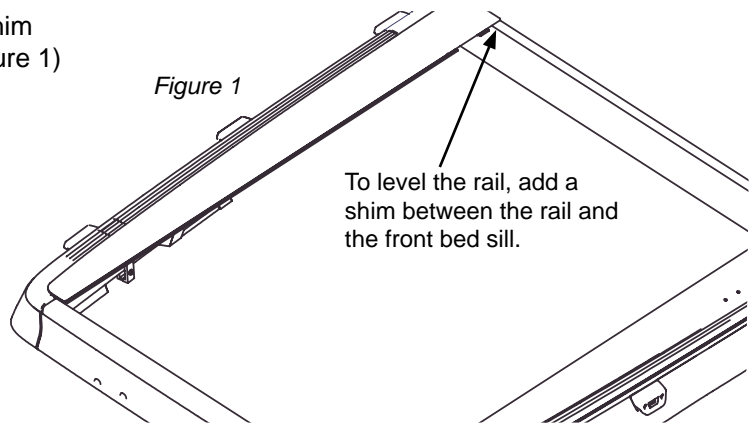

### INSTALLING THE RAIL CLAMPS:

1. Looking at the underside of the rail and truck bed rail, locate the factory open slot in the truck bed rail.
2. Install the clamps through these slots in the truck bed. (Figure 2)
3. Hold the rail down and the clamp up while tightening the bolts in the clamps. Do Not Over Tighten. (Figure 3)

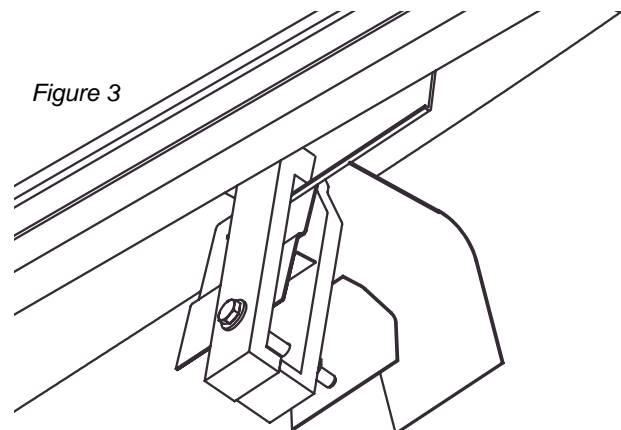
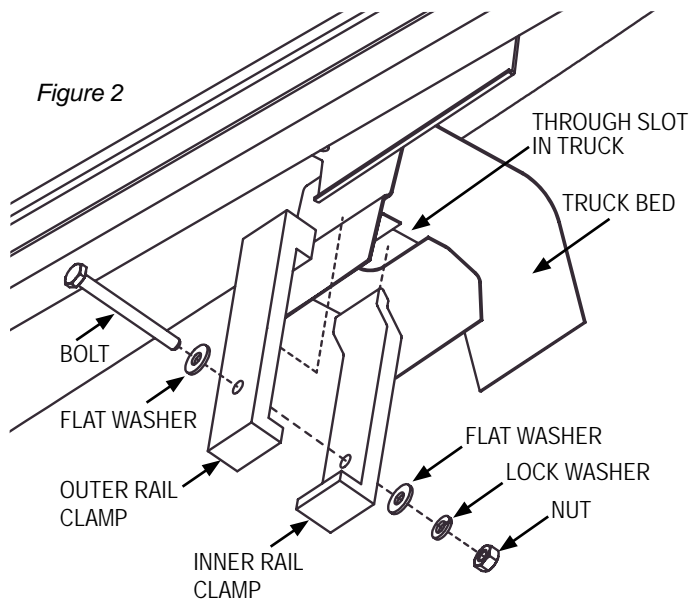

Be sure to hold the rail *down* and the clamp *up* while tightening the bolts in the clamps. This will insure a snug fit to the Truck bed. **Do Not Over Tighten the Clamps.**



#1 RETRACTABLE TRUCK BED COVER

If you have any questions please call our technical support at: **800-338-3697**