

# BEDLOCKER®

ELECTRIC RETRACTABLE TRUCK BED COVER

## HONDA RIDGELINE INSTALLATION INSTRUCTIONS



**#1 RETRACTABLE TRUCK BED COVER**

**(800) 338-3697**

**[www.paceedwards.com](http://www.paceedwards.com)**

Pace Edwards Company  
2400 Commercial Blvd.  
Centralia WA 98531

### TABLE OF CONTENTS

Tools Required for Assembly .....	2
Before You Start .....	2
Packaging Contents .....	2
STEP 1: Remove Contents from Box .....	2
STEP 2: Install Wiring Harness .....	3
STEP 3: Attach Rail Brackets & Rails to Canister ...	4
STEP 4: Install Cab End Rail Brackets.....	5
STEP 5: Installing Cover in Truck Bed .....	5
STEP 6: Lubricating the Rails.....	6
STEP 7: Connect the Electronics .....	6
STEP 8: Installing Drain Tubes.....	6
STEP 9: Install Top Cover .....	7
Release Handle Instructions .....	7
Helpful Maintenance Hints .....	7
Warranty Statement.....	8

## TOOLS REQUIRED FOR ASSEMBLY:

3/8" wrench or socket    Razor box Knife    Drill w/ 3/4" taper drill or step drill bit  
#2 Phillips screwdriver    #40 Torx wrench  
Wire Cutters    #50 Torx wrench

## BEFORE YOU START:

Read the instructions carefully before you start. Due to the custom fit of this truck bed cover the installation will require a second person to help in running the wire and placing the canister in the truck bed. If you have questions regarding the installation please call our Technical Support Line at (800) 338-3697.

## PACKAGING CONTENTS:

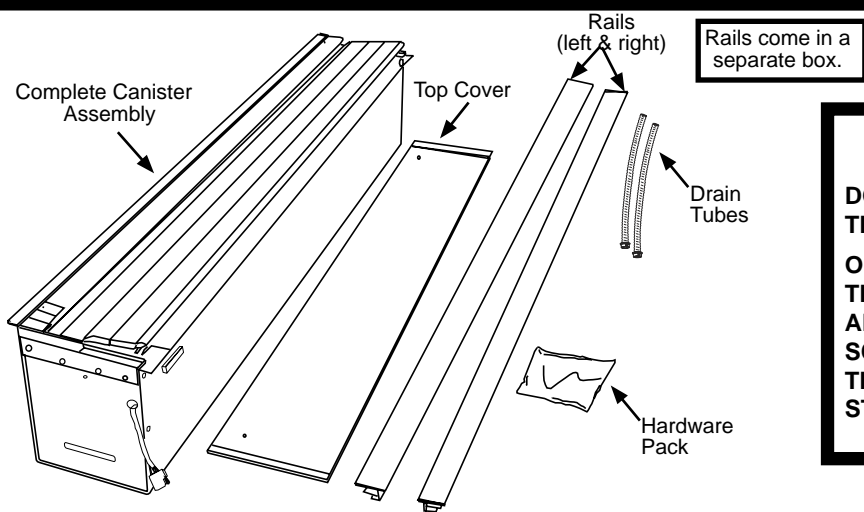

**DO NOT USE A KNIFE TO OPEN THE RAIL BOX.**  
**OPEN THE RAIL BOX ALONG THE LENGTH OF THE BOX AND LIFT RAILS OUT TO AVOID SCRATCHING THE SURFACE OF THE RAILS ON THE PACKAGE STAPLES.**

## OPTIONAL WIRING HARNESS FOR DASHBOARD SWITCH:

The BedLocker also offers an optional wire harness (**part # BL1120**) to manually operate the tonneau cover from inside the cab of your truck.

This harness is designed to plug into the custom-built electronics control box mounted inside the canister.

Thread the plug through the side of the canister and connect it to the grey/violet plug. Make sure to secure the loose wires inside the canister away from the gear and blanket.

Then run the wire to the cab and attach under the dash in a suitable location.

## STEP 1: REMOVE CONTENTS & PLYWOOD PACKAGING

Remove the canister and top cover from the box.

Remove components from inside the canister. Perform a quick inventory to insure all parts are there.

Using the 3/8" wrench or socket remove the 2 bolts holding the plywood packaging supports on the ends of the canister. Discard plywood packaging supports and bolts.

**DISCARD PLYWOOD PACKAGING AND BOLTS!**

## STEP 2: INSTALL WIRING HARNESS

### HARDWARE USED:

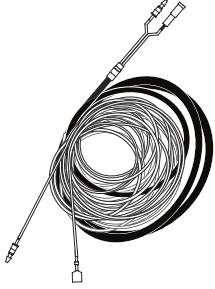

WIRE HARNESS x 1



ZIP TIES x 5

(If the optional wire harness **Part# BL1120** is used, you may want to tape it to the main harness to ease having to pull them through the bottom of bed separately).

In the truck bed, remove the 2 factory bolts from both of the front upper tie down brackets using a #50 torx bit and set aside (for step 4).

Remove the 6 factory bolts using a #40 torx bit that hold the front bed panel to the cab. Temporarily remove front bed panel.

Find the wire harness and remove the fuse holder from the harness. Tape the 2 wires together where the fuse holder was removed.

Carefully feed the end of the wire through the bottom of the bed between the cab and the bottom bed panel. (This step will take one person under the truck with a flashlight to see and grab the wire when it exits the bed while being fed down from the top.)

Run the opposite end of the wire up the left side of the bed wall to the ledge just below where the upper tie down bracket was.

Leave approximately one foot of slack inside the bed from the front bed panel after it is reinstalled. Put the front bed panel in place but leave it loose for now.

Pull the remaining slack in the harness under the truck and to the battery in the engine compartment.

Attach the fuse holder to the end of the red/positive wire.

Reinstall the 6 factory bolts in the front bed panel and tighten them up.

**(Do not attach to the battery yet.)**

Secure the harness with wire ties provided after slack from the canister has been taken out.

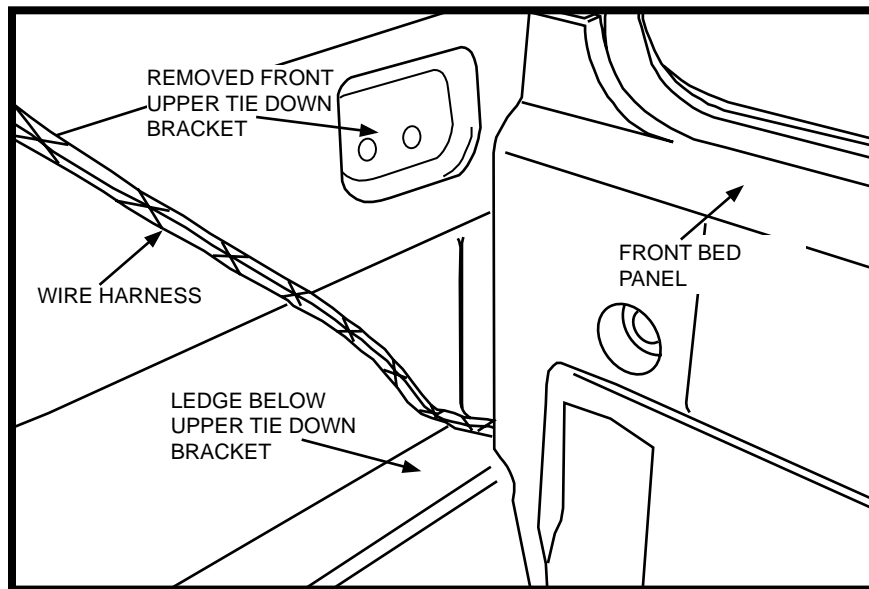

## STEP 3: ATTACH RAIL BRACKET & RAILS TO THE CANISTER

### HARDWARE USED:

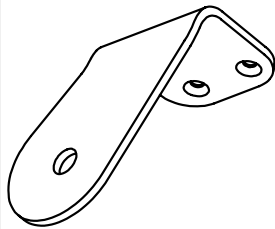

REAR RAIL BRACKET x 2

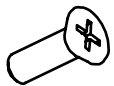

#8-32 x 1/2" SCREWS x 4

Open the rail box along the length of the box; lift rails out to avoid scratching the rail surface on the package staples.

### REMOVE PROTECTIVE PAPER ON UNDERSIDE OF RAILS. THIS IS FOR PACKAGING PURPOSES ONLY.

Find the two rear rail bracket's and four of the #8-32 X 1/2" countersunk screws in the hardware kit and attach them to each of the rails at the tailgate end. **(Notice that there is a Left hand side and a Right hand side bracket)** (Figure 3a)

Install the rails to the canister by threading the blanket in the rails, and sliding the rails into the rail grip that is attached on the inside of the canister.

Then slide the rails forward, towards the truck cab making sure that both of the rail grips are engaged. (Figure 3b)

Complete for both left and right rails.

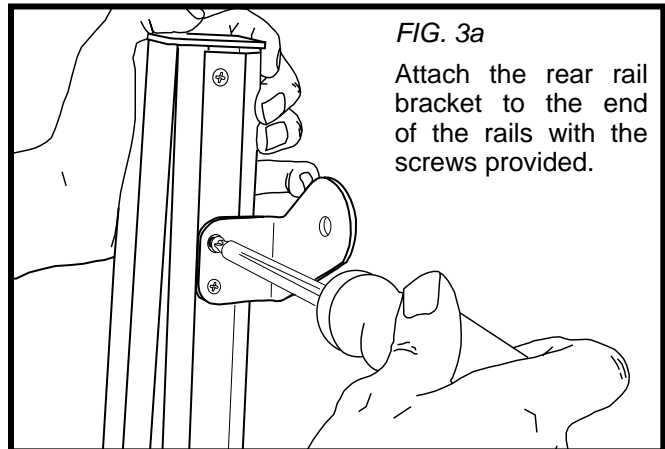

FIG. 3a

Attach the rear rail bracket to the end of the rails with the screws provided.

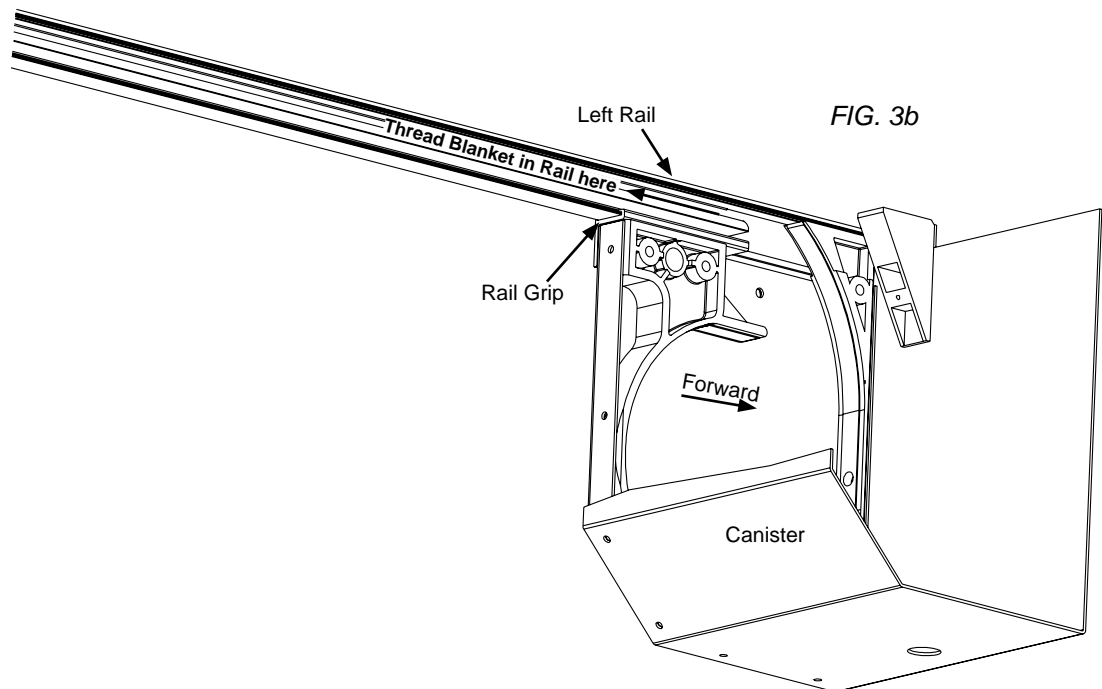
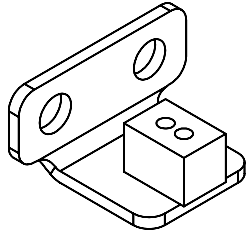

FIG. 3b

## STEP 4: INSTALL CAB END RAIL BRACKETS & PREPARE BED

### HARDWARE USED:



FRONT RAIL BRACKET x 2

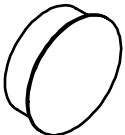

BED HOLE PLUG x 2

Find the two front rail brackets with rail mounting block attached to them in the hardware kit.

Place the front rail bracket in front (mounting block up) of the upper tie down bracket and run factory bolts back in making sure the upper tie down bracket is exactly the way it was when removed. (Figure 4a)

Find the two black bed hole plugs in the hardware kit box and put them in the two upper middle holes in the bed wall.

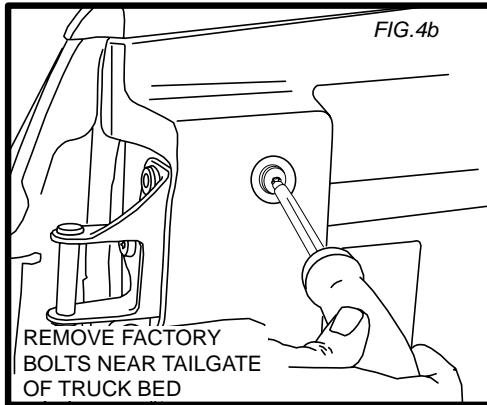
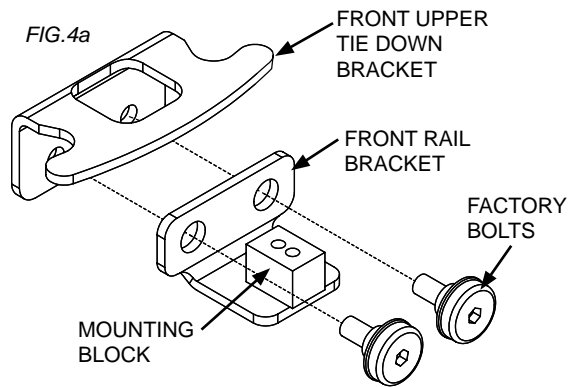

While in the truck bed remove the factory bolt in the bed wall at the tailgate end of the truck bed with the #40 torx bit. (Figure 4b)

## STEP 5: INSTALL COVER IN TRUCK BED

### HARDWARE USED:



NYLON SPACER x 2



FLAT WASHER x 2



LOCK WASHER x 2

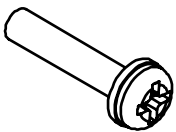

M6 x 30mm BOLTS x 2

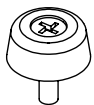

FRONT RAIL BRACKET SCREW x 2

With one person on each side of the canister grab the rails and take the cover to the center of the truck bed, place the cover inside the bed and slide the canister evenly up to the cab and in between the front upper tie down and the mounting block on the front rail bracket ending up on the lip of the bed bulkhead.

Find the two M6 x 30mm bolts, lock washers, flat washers and the two nylon spacers in the component box.

Take the M6 bolts with lock washer and flat washer and run them through each of the rear rail brackets, take the two nylon spacers and put them on the M6 bolts between the truck bed and back of the bracket (before tightening the M6 bolts be sure that the canister is tight to the bulkhead to prevent cross threading) (Figure 5a)

Tighten the two M6 bolts.

Place the two front rail bracket screws in between the hole in the upper tie down bracket and through the hole in the rail and tighten down completely. (Figure 5b)

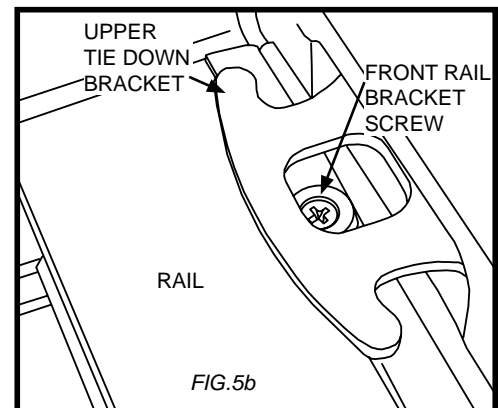
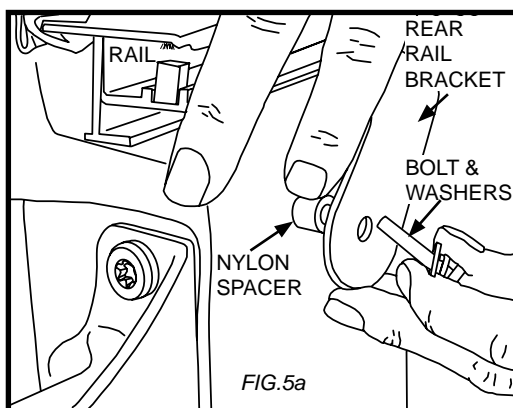

## STEP 6: LUBRICATING & PLACING THE SWEEP SEALS

Locate the sweep seals (rubber weather strips) on the rails. Apply Pace Edwards' UV Protectant (or 303 brand protectant) to a rag and wipe the underside of the sweep seal and the top of the wear strip.

Extend the cover to the tailgate. Use an Allen wrench if needed to carefully draw out the sweep seal (seal should be angled outwards toward the cover – not rolled in toward the bed rail). (Fig. 6A)

Proper care and placement of the sweep seal will ensure smooth operation of the cover. Alcohol, petroleum based or silicon-based cleaners such as Armor-All® should be avoided and ARE NOT recommended for our covers

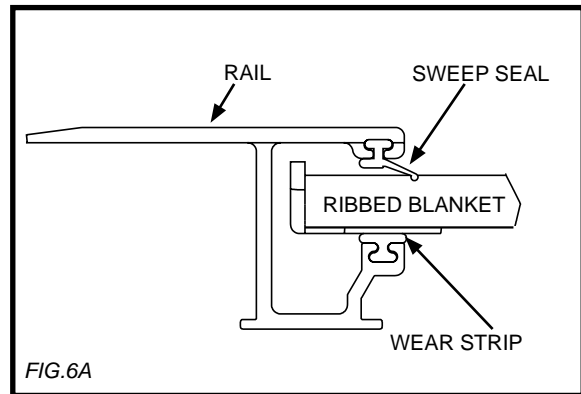

## STEP 7: CONNECTING THE ELECTRONICS

### HARDWARE USED:



2-BUTTON REMOTE KEY FOB x 2

The electronics box has been pre-mounted to the inside of the canister.

Connect the battery wire harness into the 2-wire plug at the end of the canister (**also connect the optional manual switch harness, if installed at this time**)

Attach the Red (positive) and Black (negative) wires to the battery or the truck manufacturers suggested connection points at this time.

Unit is now ready to operate.

Press the Open button to open cover and press the Close button to shut the cover.

## STEP 8: INSTALLING DRAIN TUBES

The Ridgeline has standard OE plastic/rubber access ports in the floor at the front of the truck bed. You will need to use the box knife to remove these plugs. (Figure 7a)

Once removed use a suitable drill bit (such as a taper drill or step drill) and drill or create drain tube clearance holes at 3/4" (19mm) through the removed plugs. (Figure 7b)

Ensure that the foam washer is in place on the drain tube end being inserted into the bottom of the canister (This will prevent water leakage).

Test fit the drain tube to determine the length you want to trim it. Always caution on the long side.

With the cover *opened*, insert the drain tube fittings into the pre-drilled holes on the underside of the canister by firmly pushing them in place from under the canister. Drain tube should click into place. (This is a tight fit that may require much pressure and a slight turning of the tube as it is being pushed in.)

Place the other end of the drain tube through the front access drain port plug.

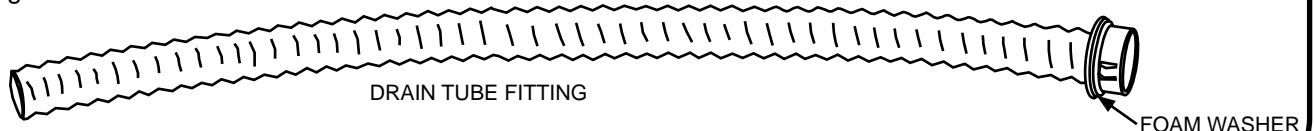
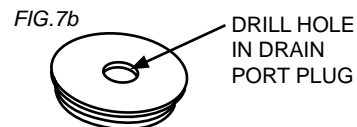
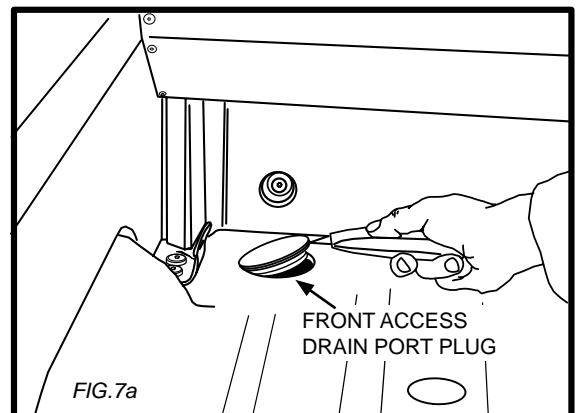

## STEP 9: ATTACHING TOP COVER

### HARDWARE USED:



BLACK TOP COVER  
SCREW x 2

Place the top cover on the canister opening and install the (2) Black Top Cover Screws into the attachment blocks mounted to the inside of the canister.

Hold the top cover tight against the cab side of the box while tightening.

(The top cover can be adjusted slightly to align evenly with the ribbed blanket)

You have now completed the installation of the Bedlocker Electric hard tonneau cover. If you have any questions please do not hesitate to call us at: (800) 338-3697 and ask for our technical service department.

## RELEASE HANDLE INSTRUCTIONS

If power is lost to the Bedlocker unit or the electric drive system fails to operate and you have to use the cover right away you can do the following to open or close the cover:

1. You will need to gain access to the release handle located on the driver side of the canister at the front of the truck bed. Once you have access to it, Pull the handle out away from the canister and pull out the handle kickstand behind it.
2. Settle the kickstand into the notch on the handle to hold the handle in place.
3. Now you should be able to push or pull the paneled blanket manually open or closed.

NOTE: The blanket will not lock unless you disengage the kickstand and lower the release handle. With the handle released the cover will move a short distance and the cover will then lock itself in place. (Cover may not lock tightly against tailgate)

This process will allow you to use the cover until power is restored. It is not meant for extended or permanent use.

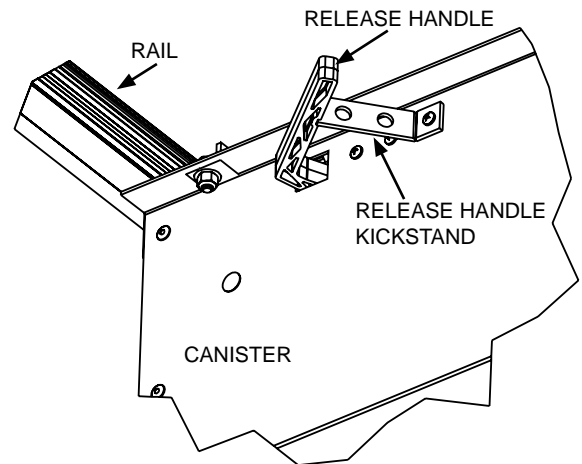

## HELPFUL MAINTENANCE HINTS

After installation, if the cover is tight or hard to open and close, the shimming may need to be re-adjusted.

Periodically remove the Top Cover and clean out the canister.

Drain tubes may become clogged overtime and should be removed and cleaned. To remove the drain tubes you must; Remove the Top Cover, close the cover to the tailgate, reach in the canister and depress the plastic retaining tabs on the drain tube fittings and push the drain tube out of the hole in the bottom of the canister. (Fig. 1)

To help keep the Bedlocker retractable tonneau cover looking its best, we recommend washing it the same as caring for your truck finish. However due to the hammer texture, removal of wax can be difficult so you should not wax your cover.

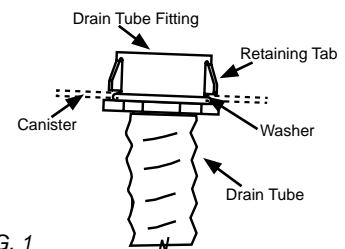

FIG. 1

## RELEASE HANDLE ASSEMBLY MAINTENANCE

Maintenance of the Release Handle Assembly requires lubrication of the coupler located inside the canister. This is done during factory assembly but may need to be done from time to time during the life of your cover.

A small lubrication hole is provided on the coupler that a fine tipped grease gun can inject a small amount of grease into. a high quality waterproof wheel bearing grease is recommended.

To get to the coupler you will need to remove the rail clamps and end caps at the end of the rails. Use the manual release handle and **manually** pull the blanket out the end of the rails until you have access to the coupler inside the canister. Grease the coupler, cycle and spin it to distribute lubricant then reverse the process to re-assemble the cover being sure to **manually** push the cover back into place in the canister. **(DO NOT USE THE MOTOR TO RUN THE BLANKET INTO THE CANISTER OR YOU WILL DAMAGE THE RIB CAPS ON THE EDGES OF THE BLANKET.)**

# CONGRATULATIONS!

Cover. We are confident that you will get many years of trouble free service from this accessory to your truck. Please take a moment to fill out the warranty registration form to activate warranty coverage of your truck bed cover.

## PACE EDWARDS PRODUCT WARRANTY

PACE EDWARDS (hereinafter referred to as the MFG.) warrants each new Pace Edwards Bedlocker®, JackRabbit®, Full-Metal-JackRabbit™, and Roll-Top-Cover® retractable truck bed cover to the original owner as follows:

**FOR A PERIOD OF THREE (3) YEARS FROM THE DATE THE UNIT IS DELIVERED TO THE FIRST PURCHASER OR PLACED INTO SERVICE AS A DEMONSTRATOR OR COMPANY UNIT:**

- Delamination of the ArmorTek deck
- Separation of the Bedlocker/Full Metal deck panels
- Failure of the Continuous Tension Spring
- Failure of the Bedlocker drive system
- All lock assemblies
- All hardware and components

**ITEMS NOT COVERED UNDER WARRANTY FOR ANY PERIOD OF TIME:**

- Rips, tears, or discoloration of the ArmorTek deck material
- Seals and gaskets
- Water intrusion from any source
- Dealer and/or purchaser installed parts and accessories

**CERTAIN CONDITIONS WILL VOID ALL WARRANTY.**

These conditions include:

- Use for any purpose other than normal private use including rental and promotion
- Altering the retractable truck bed cover in any manner without written approval of the MFG
- Misuse, negligence or accident
- Installation of any part or accessory without written approval from the MFG
- Failure to register this warranty with the MFG within fourteen (14) days from date of delivery

### CLAIM PROCEDURE

If a part fails, the purchaser should return to the selling dealer to determine if the failed part is covered under the terms of this warranty. If a Warranty Claim is necessary, the dealer will contact Pace Edwards to obtain A Return Goods Authorization. If it is impractical for the purchaser to return to the selling dealer, then the purchaser may contact the Pace Edwards Technical Assistance Help Desk at 1-800-338-3697 to determine warranty eligibility. In either event, it is the responsibility of the purchaser to obtain a Return Goods Authorization prior to returning the defective part to the MFG. The defective part, along with a copy of the original Bill of Sale and the Pace Edwards issued RGA #, must be returned PREPAID to Pace Edwards Co. 2400 Commercial Blvd. Centralia, WA 98531. After determining the validity of the warranty claim, PACE EDWARDS will ship a replacement part prepaid to the customer. Labor costs to replace defective parts are the responsibility of the purchaser.

On your purchase of a Pace Edwards Retractable Truck Bed

cover, we are confident that you will get many years of trouble free service from this accessory to your truck. Please take a moment to fill out the warranty registration form to activate warranty coverage of your truck bed cover.

### CONDITIONS AND LIMITATIONS

This warranty is subject to certain conditions and limitations including, but not limited to, the following:

- Any part of a Pace Edwards retractable truck bed cover that is found to be defective under the terms of this warranty will be repaired or replaced using either new or reconditioned parts at the discretion of the MFG.
- In determining what constitutes a failure under the terms of this warranty the decision of the MFG shall be final.
- This warranty is extended to the original purchaser only and is not transferable to subsequent purchasers.
- The MFG does not accept any responsibility in connection with the installation of any of its products by its dealers or agents.
- The MFG does not undertake responsibility to any purchaser for warranty express or implied by any of its dealers, distributors or agents beyond that which is contained herein.
- Without regard to an alleged defect of its products the MFG under any circumstances does not assume responsibility for loss of time, inconvenience, revenue, or other consequential damage including, but not limited to, expenses for telephone, food, lodging, travel, loss or damage to the vehicle the products are installed on or loss or damage to personal property of the purchaser or user of the products.
- The MFG reserves the right to make changes in the design of, improvements to, or warranty of its products without imposing any obligation upon itself to provide the same for any products theretofore manufactured.

*Some jurisdictions do not allow limitations on or exclusions to warranties, therefore some of the exclusions may not apply to you. This warranty affords you specific legal rights. You may have other legal rights that may vary from jurisdiction to jurisdiction.*

## WARRANTY REGISTRATION

Please return this completed warranty registration within 14-days to:

Or go online and register your warranty at:

[www.paceedwards.com/warranty-care](http://www.paceedwards.com/warranty-care)

Pace Edwards  
Attn: Warranty Dept.  
2400 Commercial Blvd.  
Centralia, WA 98531



NAME: \_\_\_\_\_

ADDRESS: \_\_\_\_\_

CITY: \_\_\_\_\_ PROV./STATE: \_\_\_\_\_ PC/ZIP: \_\_\_\_\_

MODEL #: \_\_\_\_\_ SERIAL #: \_\_\_\_\_

DATE OF PURCHASE: \_\_\_\_\_ PURCHASED FROM: \_\_\_\_\_ PRICE PAID: \_\_\_\_\_

CUSTOMER SIGNATURE: \_\_\_\_\_