

# SWITCHBLADE

RETRACTABLE TRUCK BED COVERS

## FORD INSTALLATION INSTRUCTIONS



**#1 RETRACTABLE TRUCK BED COVER**

**(800) 338-3697**

**[www.paceedwards.com](http://www.paceedwards.com)**

Pace Edwards Company  
2400 Commercial Blvd.  
Centralia WA 98531

### TABLE OF CONTENTS

Tools Required for Assembly .....	2
Before You Start .....	2
Drain Hole Locations .....	2
STEP 1: Remove From Packaging, and Hardware and Packaging Contents .....	2
STEP 2: Positioning Canister .....	3
STEP 3: Installing Rails .....	3
STEP 4: Installing Clamps.....	3
STEP 5: Attaching the Pull Strap.....	4
STEP 6: Lubricating & Placing Sweep Seals .....	5
STEP 7: Installing Drain Tubes.....	5
STEP 8: Install Top Cover & Velcro .....	5
Operating Instructions .....	6
Helpful Maintenance Hints .....	6
Warranty Statement.....	7

## TOOLS REQUIRED FOR ASSEMBLY:

7/16" wrench or socket  
#2 Phillips screwdriver

Tape measure  
Utility Knife

Side Cut or Needle Nose Pliers

*Note: There should be no drilling into the truck body needed on most standard or full-size trucks .*

## BEFORE YOU START:

Read the instructions carefully before you start. If you have questions regarding the installation please visit our website [www.paceedwards.com](http://www.paceedwards.com) or call our Technical Support Line at (800) 338-3697.

## DRAIN HOLE LOCATIONS:

The Switchblade is designed to carry rainwater from the cover into the canister and then out through the drains. Most truck models have standard OE drain holes or plastic/rubber access ports in the front of the truck bed. Check to make sure your truck has the OE drain holes so that drilling into the sheet metal is not required. If drilling is necessary, be sure to check the underside of the truck bed for the best location. The holes should be located near the side and as far forward as possible. Use a drill bit suitable for sheet metal (such as a taper drill or step drill). Drill drain tube clearance holes at 3/4" (19mm). This will need to be done before installing the cover.

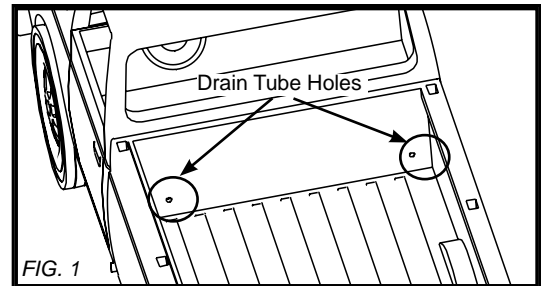

## STEP 1: REMOVE FROM PACKAGING AND REVIEW CONTENTS

A complete unit will consist of one canister box (marked box 1 of 2) and one rail box (marked box 2 of 2). Remove the Top Cover, Canister, Clamp pack, hardware pack, and drain tubes from the canister box. Remove the rails from the rail box (see caution below). Perform a quick inventory of the packaging contents to insure all parts are there.

**CAUTION!**

**TO AVOID SCRATCHING THE SURFACE OF THE RAILS, DO NOT SLIDE THEM OUT THE END OF THE BOX. OPEN THE BOX ALONG THE LENGTH, USE PLIERS TO PULL THE STAPLES, LIFT THE RAILS OUT. DO NOT USE A KNIFE TO CUT THE BOX OPEN.**

**CAUTION!**

## PACKAGING CONTENTS:

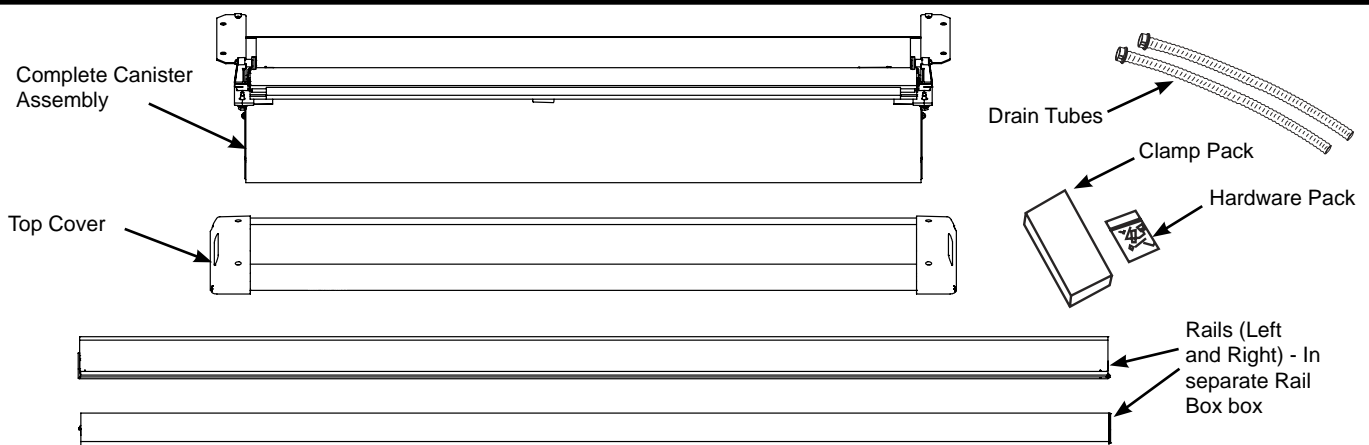

## STEP 2: POSITIONING CANISTER

Use the Pull Strap and one canister flange to lift and steady the unit. Wrap the Pull Strap around the center of the canister a couple times and double it up in your hand.



Place the Canister in truck bed just behind the cab and center it from side to side. Ensuring that the canister is centered in the bed will help assemble the rails to canister in the next step.

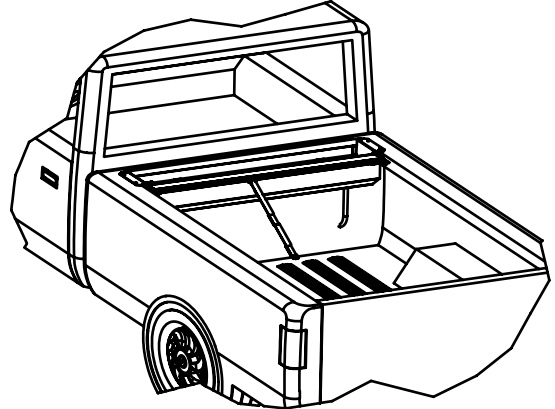

## STEP 3: INSTALLING RAILS

### HARDWARE USED:

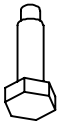

1/4-20 x 1"  
RAIL BOLT x 2



1/4" LOCK WASHER x 2



1/4" FLAT WASHER x 2

Remove the protective paper on the underside of the Rail flanges. This for packaging purposes only. The rails shipped with plastic shims pre-installed to the Rail Brackets for proper spacing. Ensure those shims are in place.

Next identify the left and right side rails. The plastic rail endcap should be towards the tailgate while the rail flange, shims and brackets towards the outside of the truck bed. Install the rails by first guiding Handle Assembly into the open channel of the rail and then sliding the rail against the blanket guide on the canister. Attach the rail to the canister using the rail bolt, lock washer and flat washer through the blanket guide and into the bottom of the rail.

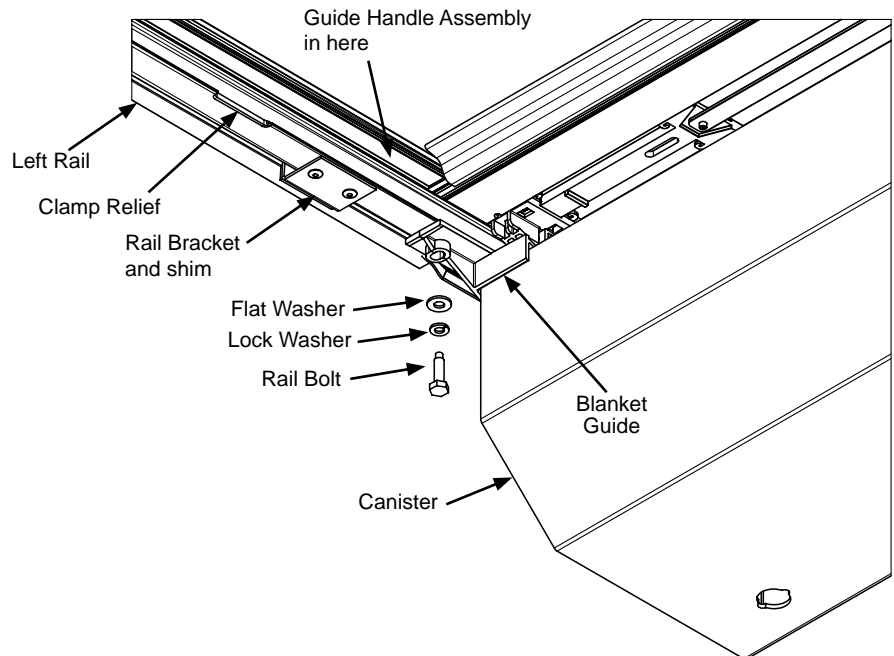

FIG. 3a

## STEP 4: INSTALLING CLAMPS

Secure the rails to the truck bed by installing two clamp assemblies per rail. Slide the Clamp Grip onto the Rail at the Clamp Relief and then slide it towards the Rail Bracket and Shim (Fig 4E and 4F). Then assemble the rest of the clamp parts as shown below (Fig 4C). Rotate the Pivot Arm of the clamp as shown below (Fig 4D), this will pull the rail tight against the truck bed, and tighten the Clamp Bolt to a snug fit.

Before fully tightening the rail clamps set the Rail End Caps about 1/16 inch from the tailgate. This space will allow for overstroke when closing the tailgate. Once everything is in position rotate the Pivot Arm and tighten the Clamp Bolts completely. **Do NOT tighten over 120 inch-pounds!**

Finally, check for proper spacing by measuring between the rails at the canister and the tailgate end of the rails (Fig 4A). The measurements should be equal to or less than those in Fig 4B. The Rail Brackets and Shims have been pre-installed to achieve the proper Between the Rail dimension (BR) when placed on an average factory truck bed. However, not all truck beds are average dimensionally and some have optional plastic caps or over the rail spray-in

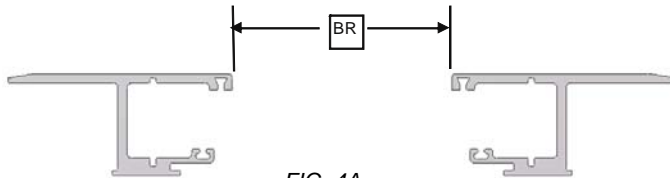

FIG. 4A

Part number is on the serial number label in the upper left corner of the canister (looking from tailgate).

PART NUMBER	BETWEEN RAILS (BR)
SW2028	58 9/16
SW2029	58 9/16
SW2030	58 9/16

FIG. 4B

Another way to ensure proper spacing is to check the side to side play of the handle assembly at the canister and at the tailgate end of the rails. There should be, at the minimum, enough play to allow the cover to move freely with no drag and at a maximum 1/8 inch per side. More than 1/8 inch per side may result in the cover opening unintentionally and in severe cases it may fall between the rail tracks and damage the cover. **There are shims on the brackets that can be removed if the unit is too tight and shims in the hardware pack that can be added if too loose.**

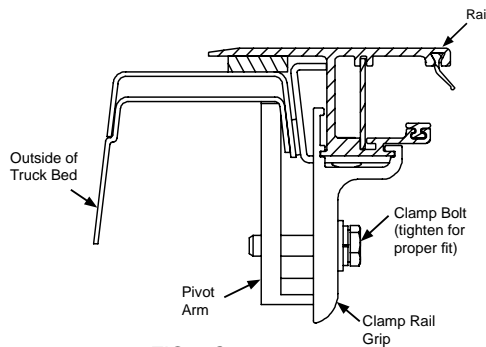

FIG. 4C

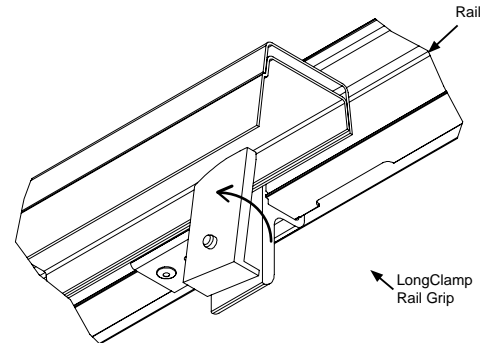

FIG. 4D

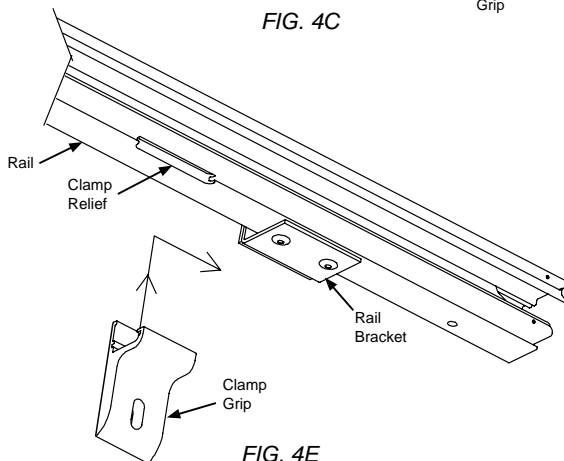

FIG. 4E

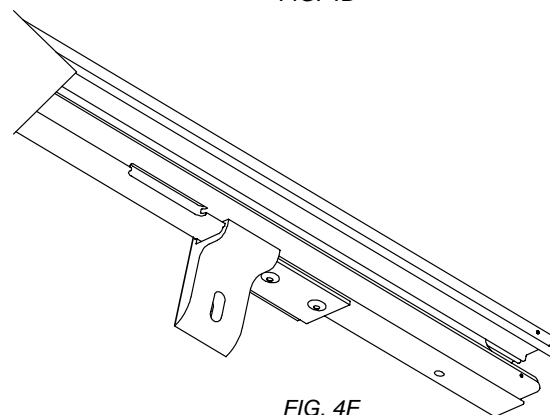

FIG. 4F

## STEP 5: ATTACH THE PULL STRAP

Attach your pull strap to either of the clamps (left or righthand side) at the tailgate end of the rails by looping it through the assembly and pressing the two velcro strips together. This will ensure the pull strap will always be in easy reach when trying to close the cover.

## STEP 6: LUBRICATING & PLACING THE SWEEP SEALS

Locate the sweep seals (rubber weather strips) on the rails. Open the provided 303 brand protectant sponge pack (find it adhered to the underside of the top cover) and wipe the underside of the sweep seal and the top of the wear strip.

Extend the cover to the tailgate. Use an Allen wrench if needed to carefully draw out the sweep seal (seal should be angled outwards toward the cover – not rolled in toward the bed rail). (Fig. 6A)

Proper care and placement of the sweep seal will ensure the smooth operation of the cover. Alcohol, petroleum based or silicon-based UV Protectants such as Armor-All® should be avoided and ARE NOT recommended for our covers.

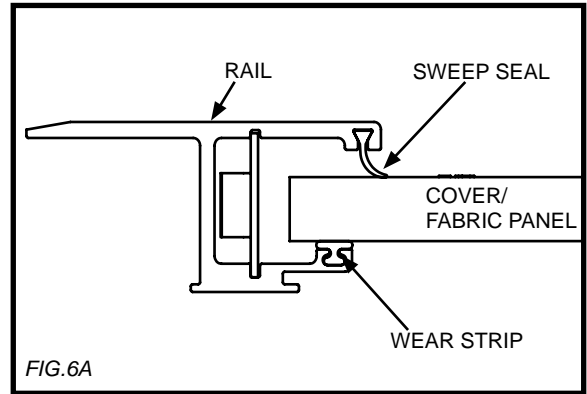

## STEP 7: INSTALLING DRAIN TUBES

First, ensure that the Foam Washer is in place on the Drain Fitting as this washer will help prevent water leakage. Next, test fit the drain tube to determine the length you want to trim it. Always caution on the long side. Trim the end that will be inserted through the truck bed using the wire cutters or a utility knife.

With the cover *opened*, insert the drain tube fittings into the pre-drilled holes on the underside of the canister by pushing them in place from under the canister. Drain Fitting should click into place.

Place the other end of the drain tube through the plastic/rubber access port or through the pre-drilled holes in the floor or the front wall of the truck bed. If routing through the front wall, ensure that the drain tubes are inserted and directed down so water flows out of the truck.

To remove the drain tubes reach under the canister, grab the drain tube fitting and turn it while applying light downward pressure. When the retaining tabs align with notches in the bottom of the canister the Drain Tube and Fitting will drop out.

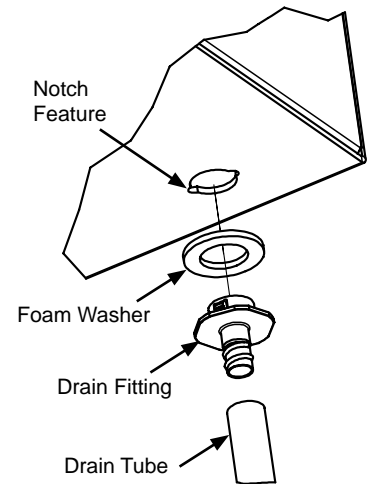

## STEP 8: ATTACHING TOP COVER & VELCRO TO PULL STRAP

### HARDWARE USED:



4' VELCRO STRIP



BLACK TOP COVER SCREW x 4

Place the Top Cover on the canister and install with the four black Top Cover screws through the top cover endcaps and into the panel nuts on the canister flanges.

Retract the cover to the fully open position.

Attach the 4" Velcro strip onto the Velcro strip already attached to the pull strap.

Pull the pull strap over to the driver's side rail and remove the tape from the 4" Velcro strip.

Then apply the Velcro strip onto the underside of the rail at your desired position.

This will hold the pull strap off of the floor and out of the way when cargo is being stored in the truck bed.

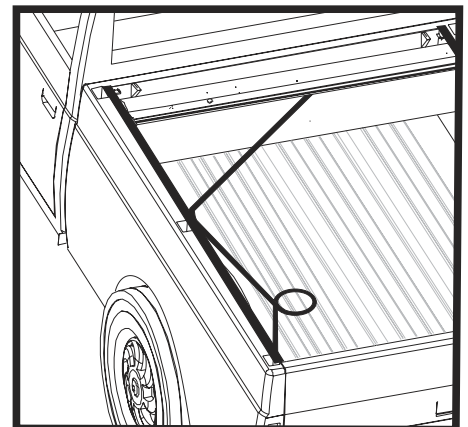

**You have now completed the installation of your Switchblade Retractable tonneau cover. If you have any questions please do not hesitate to call us at: (800) 338-3697 and ask for our technical service department.**

## OPERATING INSTRUCTIONS

1. To open the cover, open your tailgate and squeeze (pinch) together the Handle Tabs in the center on the underside of the cover. This retracts the latches and the cover is free to roll open into the canister.
2. To close the cover, pull on the strap to draw it back toward the tailgate. When it is within easy reach, grasp the handle by the hand grip and pull the cover to the latching position against the tailgate.
3. To secure cargo under the cover in the bed simply lock your tailgate

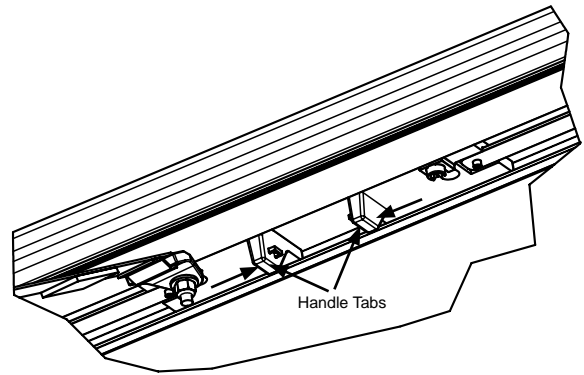

## HELPFUL MAINTENANCE HINTS

To assure quiet, smooth operation, apply a small amount of Pace Edwards' UV Protectant (or 303 brand protectant) to a rag and wipe the underside of the sweep seal and the top of the wear strip. Re-apply if the cover begins squeaking or sticking during use. (Fig. 1)

Proper care and placement of the sweep seal will ensure the smooth operation of the cover.

It is important to open and close the cover regularly; the spring that operates the cover is self-lubricated and regular use assures that it stays in proper working condition.

Periodically remove the Top Cover and clean out the canister.

Drain tubes may become clogged over time and should be removed and cleaned. To remove the drain tubes reach under the canister, grab the drain tube fitting and turn it while applying light downward pressure. When the retaining tabs align with notches in the bottom of the canister the Drain Tube and Fitting will drop out. (Fig. 2 and/or Fig.7A)

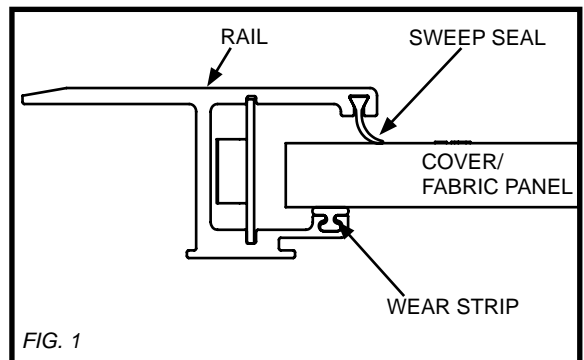

FIG. 1

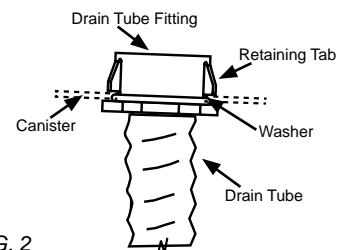

FIG. 2

To help keep the SWITCHBLADE cover looking its best, we recommend washing it the same as caring for your truck finish. However you should not wax your cover. Using a citrus-based vinyl cleaner and protectant such as Pace Edwards Brand or the 303 brand will keep your cover looking like new. Alcohol, petroleum based or silicon-based UV Protectants such as Armor-All should be avoided and ARE NOT recommended for our covers. They will cause the cover to fade more sometimes crack.

# CONGRATULATIONS!

On your purchase of a Pace Edwards Retractable Truck Bed Cover. We are confident that you will get many years of trouble free service from this accessory to your truck. Please take a moment to fill out the warranty registration form to activate warranty coverage of your truck bed cover.

## PACE EDWARDS PRODUCT WARRANTY

PACE EDWARDS (hereinafter referred to as the MFG.) warrants each new Pace Edwards Switchblade® retractable truck bed cover to the original owner as follows:

**FOR A PERIOD OF ONE (1) YEAR FROM THE DATE THE UNIT IS DELIVERED TO THE FIRST PURCHASER OR PLACED INTO SERVICE AS A DEMONSTRATOR OR COMPANY UNIT:**

- Delamination of the ArmorTek deck
- Failure of the Continuous Tension Spring
- All hardware and components

**ITEMS NOT COVERED UNDER WARRANTY FOR ANY PERIOD OF TIME:**

- Rips, tears, or discoloration of the ArmorTek deck material
- Seals and gaskets
- Water intrusion from any source
- Dealer and/or purchaser installed parts and accessories

**CERTAIN CONDITIONS WILL VOID ALL WARRANTY.**

These conditions include:

- Use for any purpose other than normal private use including rental and promotion
- Altering the retractable truck bed cover in any manner without written approval of the MFG
- Misuse, negligence or accident
- Installation of any part or accessory without written approval from the MFG
- Failure to register this warranty with the MFG within fourteen (14) days from date of delivery

### CLAIM PROCEDURE

If a part fails, the purchaser should return to the selling dealer to determine if the failed part is covered under the terms of this warranty. If a Warranty Claim is necessary, the dealer will contact Pace Edwards to obtain A Return Goods Authorization. If it is impractical for the purchaser to return to the selling dealer, then the purchaser may contact the Pace Edwards Technical Assistance Help Desk at 1-800-338-3697 to determine warranty eligibility. In either event, it is the responsibility of the purchaser to obtain a Return Goods Authorization prior to returning the defective part to the MFG. The defective part, along with a copy of the original Bill of Sale and the Pace Edwards issued RGA #, must be returned PREPAID to Pace Edwards Co. 2400 Commercial Blvd. Centralia, WA 98531. After determining the validity of the warranty claim, PACE EDWARDS will ship a replacement part prepaid to the customer. Labor costs to replace defective parts are the responsibility of the purchaser.

### CONDITIONS AND LIMITATIONS

This warranty is subject to certain conditions and limitations including, but not limited to, the following:

- Any part of a Pace Edwards retractable truck bed cover that is found to be defective under the terms of this warranty will be repaired or replaced using either new or reconditioned parts at the discretion of the MFG.
- In determining what constitutes a failure under the terms of this warranty the decision of the MFG shall be final.
- This warranty is extended to the original purchaser only and is not transferable to subsequent purchasers.
- The MFG does not accept any responsibility in connection with the installation of any of its products by its dealers or agents.
- The MFG does not undertake responsibility to any purchaser for warranty express or implied by any of its dealers, distributors or agents beyond that which is contained herein.
- Without regard to an alleged defect of its products the MFG under any circumstances does not assume responsibility for loss of time, inconvenience, revenue, or other consequential damage including, but not limited to, expenses for telephone, food, lodging, travel, loss or damage to the vehicle the products are installed on or loss or damage to personal property of the purchaser or user of the products.
- The MFG reserves the right to make changes in the design of, improvements to, or warranty of its products without imposing any obligation upon itself to provide the same for any products theretofore manufactured.

*Some jurisdictions do not allow limitations on or exclusions to warranties, therefore some of the exclusions may not apply to you. This warranty affords you specific legal rights. You may have other legal rights that may vary from jurisdiction to jurisdiction.*

# WARRANTY REGISTRATION

Please return this completed warranty registration within 14-days to:

Or go online and register your warranty at:  
[www.pace-edwards.com/Warranty-Care](http://www.pace-edwards.com/Warranty-Care)

**Pace Edwards**  
**Attn: Warranty Dept.**  
**2400 Commercial Blvd.**  
**Centralia, WA 98531**

NAME: \_\_\_\_\_

ADDRESS: \_\_\_\_\_

CITY: \_\_\_\_\_ PROV./STATE: \_\_\_\_\_ PC/ZIP: \_\_\_\_\_

MODEL #: \_\_\_\_\_ SERIAL #: \_\_\_\_\_

DATE OF PURCHASE: \_\_\_\_\_ PURCHASED FROM: \_\_\_\_\_ PRICE PAID: \_\_\_\_\_

CUSTOMER SIGNATURE: \_\_\_\_\_

---

2400 Commercial Blvd, Centralia, WA 98531 USA  
(360) 736-9991 (main) ♦ (360) 736-9992 (fax)  
**(800) 338-3697** (toll-free)  
[www.paceedwards.com](http://www.paceedwards.com)

*Thank you for choosing products by...*



**#1 RETRACTABLE TRUCK BED COVER**