

PACE EDWARDS RETRACTABLE UTILITY BED COVER MEASUREMENT FIT ORDER FORM

IMPORTANT! Due to the variances in manufacturing and aftermarket bedliners, all dimensions must be taken from the actual service body bed being used in the installation of the Utility Bedlocker. If there are any questions on any of the below please call us. We will help.

(PLEASE TYPE OR PRINT NEATLY)

CONTACT NAME:		COMPANY NAME:
ADDRESS:		
CITY:	STATE:	ZIP:
PHONE:	FAX:	EMAIL:

FITS MOST STANDARD 8' & 9' SERVICE BODY TRUCK BEDS

TAILGATE STYLE

The Utility Bedlocker vertical rail (that runs behind the tailgate) will extend all the way to the truck bed floor unless otherwise specified by the customer.

NON-SQUARE BOX DESIGN

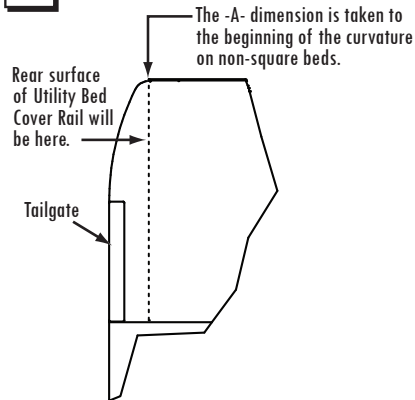

OUTSIDE MOUNTED TAILGATE

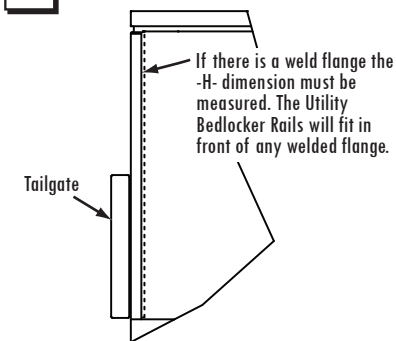

FLUSH MOUNTED TAILGATE

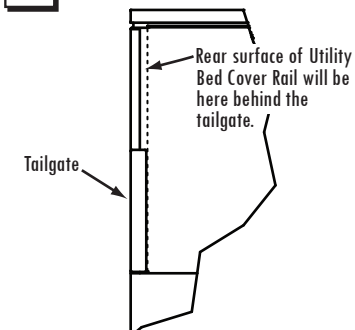

SPECIFY COVER TYPE & RAIL STYLE:

MANUAL COVER ELECTRIC COVER STANDARD RAILS OPTIONAL EXPLORER RAILS

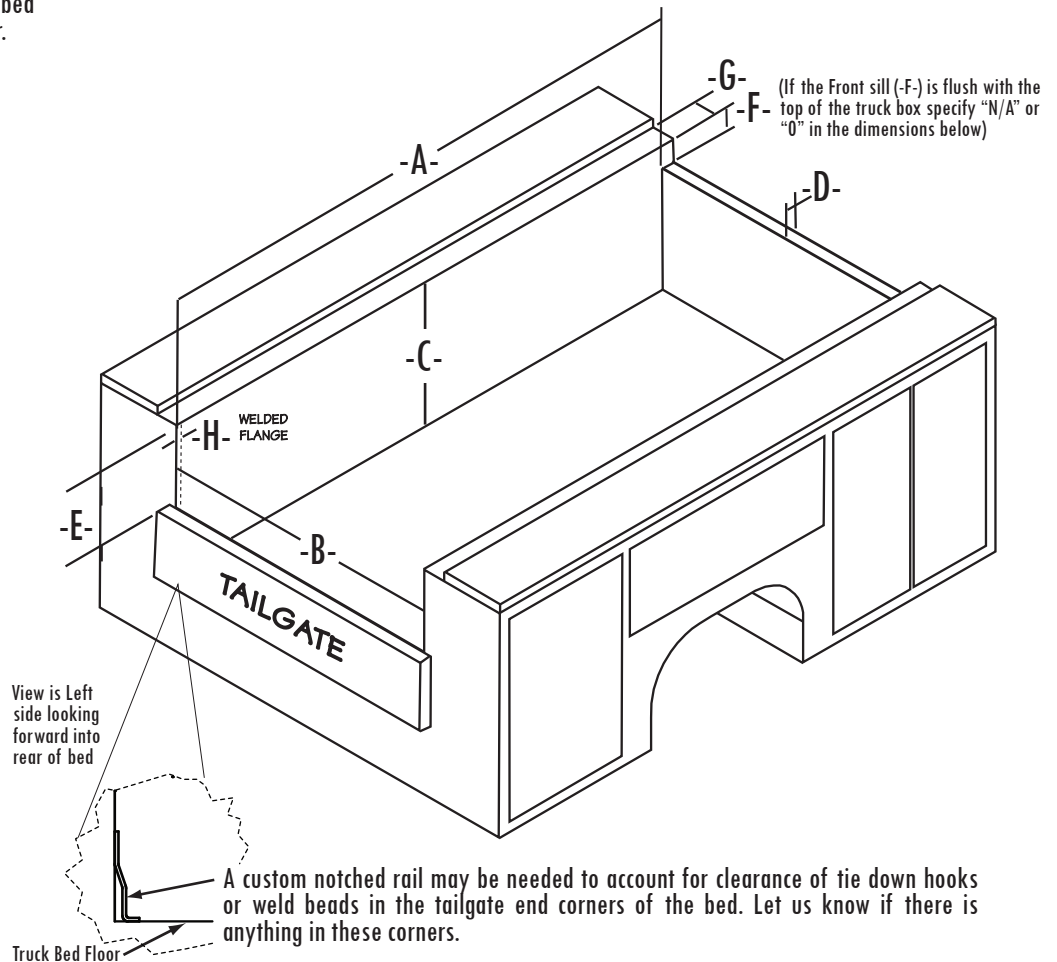

MAKE ALL MEASUREMENTS IN INCHES ACCURATE TO WITHIN 1/16TH OF AN INCH.

A		C		F	
B - Front		D - Sill		G	
B - Rear		E		H	

Please print neatly or type the dimensions above and fax back to us at (360) 237-1503