

ROLL-TOP-COVER®

RETRACTABLE HARD TRUCK BED COVERS

CLAMP ON RAIL & CANISTER INSTALLATION INSTRUCTIONS

RAIL CLAMP INSTALLATION INSTRUCTIONS

(Please follow the Roll-Top-Cover Installation Instructions through STEP 2 before installing the rail clamps. Then proceed with the below:)

1. Install guide strips* inside the rails before installing the rails. Do Not Tighten completely yet. (see STEP 4 of the Roll-Top-Cover Installation Instructions)
2. Close the tailgate and position rails so they make contact with the tailgate.
3. Shim rails (if needed) between the rail and the truck at each clamp location so that the top of the rail is level and there is the same measurement between the rails at the front (cab end) of the truck bed and between the rails at the tailgate end of the truck bed.
4. Install Inner Rail Clamp through the slot in the bottom of the rail. Hook the lower groove of the Inner Rail Clamp onto the lip of the rail. (Fig. 1)
5. Tighten bolt and rotate the Outer Rail Clamp clockwise to tighten rail securely against truck bed rail. (Note: the Outer Rail Clamp may not rotate straight up and down.)

*Guide strips are not shown in drawings at right.

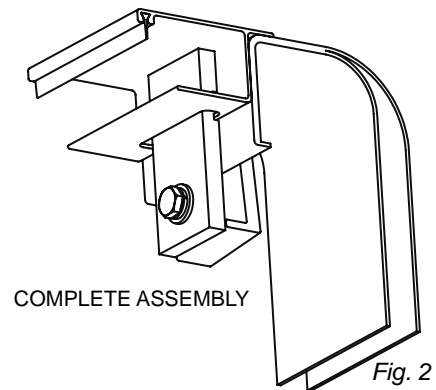
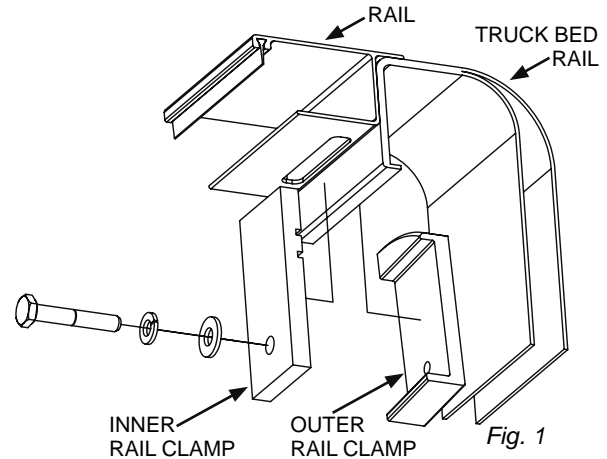

CANISTER CLAMP INSTALLATION INSTRUCTIONS

1. Center the canister side-to-side on the truck bed and fasten it in place with the canister clamps. The canister clamp may be different in some vehicles.
2. Use one clamp per side of canister. Install ¼ - 20 bolt with fender washer through one of the slots in each end of the canister and attach the Canister Clamp. The canister clamp can be installed with either side up, depending on the gap between the canister and the truck rail. (Fig. 3)
3. Proceed to STEP 6: INSTALL LOCK ARM ASSEMBLY in the Roll-Top-Cover installation instructions and continue from there with the rest of the installation.

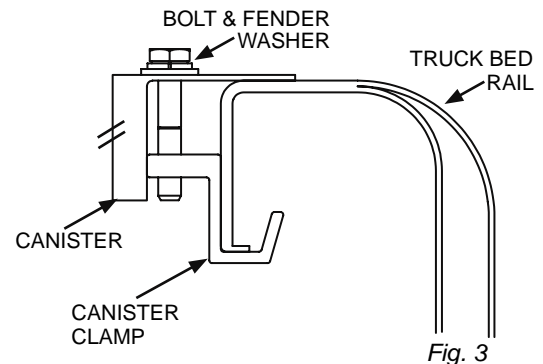

(800) 338-3697
www.paceedwards.com

Pace Edwards Company
2400 Commercial Blvd.
Centralia WA 98531



#1 RETRACTABLE TRUCK BED COVER

Part #: RTC-CLAMP-INSTALL 066